

# Service Manual

## Air Conditioner

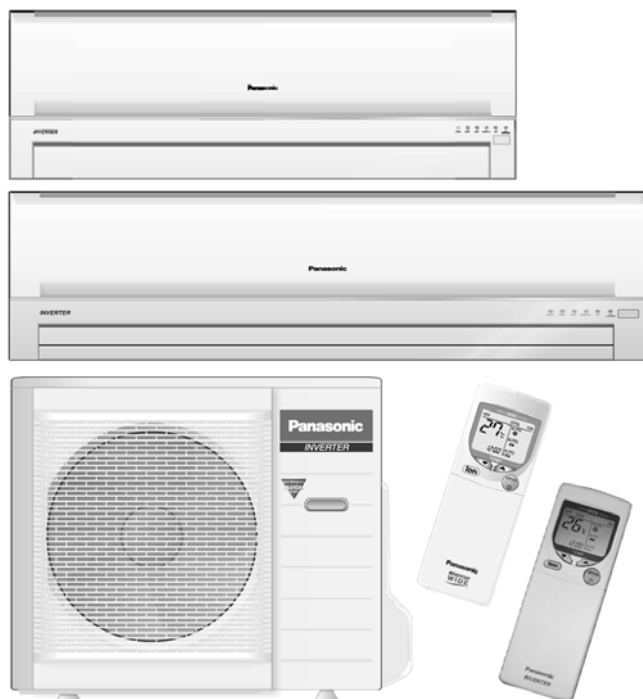

**CS-E15DKEW CU-E15DKE**  
**CS-E18DKEW CU-E18DKE**  
**CS-E21DKES CU-E21DKE**

### **⚠ WARNING**

This service information is designed for experienced repair technicians only and is not designed for use by the general public. It does not contain warnings or cautions to advise non-technical individuals of potential dangers in attempting to service a product. Products powered by electricity should be serviced or repaired only by experienced professional technicians. Any attempt to service or repair the product or products dealt with in this service information by anyone else could result in serious injury or death.

### **⚠ PRECAUTION OF LOW TEMPERATURE**

In order to avoid frostbite, be assured of no refrigerant leakage during the installation or repairing of refrigeration circuit.

## CONTENTS

	Page		Page
<b>1 Features</b> .....	2	<b>5 Refrigeration Cycle Diagram</b> .....	15
<b>2 Functions</b> .....	3	<b>6 Block Diagram</b> .....	16
2.1. Remote Control .....	3	<b>7 Wiring Diagram</b> .....	17
2.2. Indoor Unit .....	4	<b>8 Operation Details</b> .....	18
2.3. Outdoor Unit .....	5	8.1. Basic Function .....	18
<b>3 Product Specifications</b> .....	6	8.2. Protection Control Features .....	35
3.1. CS-E15DKEW CU-E15DKE .....	6	<b>9 Operating Instructions</b> .....	47
3.2. CS-E18DKEW CU-E18DKE .....	8	9.1. CS-E15DKEW .....	47
3.3. CS-E21DKES CU-E21DKE .....	10	9.2. CS-E18DKEW CS-E21DKES .....	53
<b>4 Dimensions</b> .....	12	<b>10 Installation And Servicing Air Conditioner Using R410A</b> .....	59
4.1. Indoor Unit & Remote Control .....	12	10.1. Outline .....	59
4.2. Outdoor Unit .....	14	10.2. Tools For Installing/Servicing Refrigerant Piping .....	60

### 3 Product Specifications

#### 3.1. CS-E15DKEW CU-E15DKE

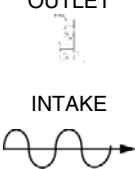
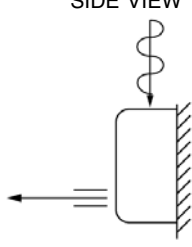
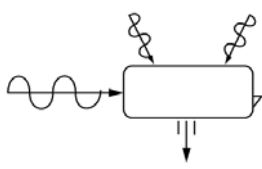
		Unit	CS-E15DKEW	CU-E15DKE
Cooling Capacity		kW kcal/h BTU/h	4.40 (0.90 - 5.00) 3,780 (770 - 4,300) 15,000 (3,070 - 17,100)	
Heating Capacity		kW kcal/h BTU/h	5.50 (0.90 - 7.10) 4,730 (770 - 6,110) 18,800 (3,070 - 24,200)	
Moisture Removal		l/h Pint/h	2.4 (5.1)	
Power Source (Phase, Voltage, Cycle)		ø V Hz	Single 230 50	
Airflow Method		<p>OUTLET</p>  <p>INTAKE</p>	<p>SIDE VIEW</p> 	<p>TOP VIEW</p> 
Air Volume	Lo	m <sup>3</sup> /min (cfm)	Cooling; 7.4 (260) Heating; 8.8 (310)	—
	Me	m <sup>3</sup> /min (cfm)	Cooling; 9.2 (320) Heating; 10.3 (360)	—
	Hi	m <sup>3</sup> /min (cfm)	Cooling; 11.0 (390) Heating; 11.8 (420)	Cooling; 48.5 (1,710) Heating; 46.8 (1,650)
Noise Level		dB (A)	Cooling; High 43, Low 32 Heating; High 43, Low 35	Cooling; 46 Heating; 46
		Power level dB	Cooling; High 54 Heating; High 54	Cooling; High 59 Heating; High 59
Electrical Data	Input Power	W	Cooling; 1,370 (215 - 1,600) Heating; 1,570 (245 - 2,250)	
	Running Current	A	Cooling; 6.3 Heating; 7.1	
	EER	W/W	Cooling; 3.21 (4.19 - 3.13)	
		BTU/hW	Cooling; 10.9 (14.3 - 10.7)	
	COP	W/W	Heating; 3.50 (3.67 - 3.16)	
		BTU/hW	Heating; 12.0 (12.5 - 10.8)	
Starting Current		A	7.3	

		Unit	CS-E15DKEW	CU-E15DKE	
Piping Connection Port (Flare piping)		inch	G ; Half Union 1/2"	G ; 3-way valve 1/2"	
		inch	L ; Half Union 1/4"	L ; 2-way valve 1/4"	
Pipe Size (Flare piping)		inch	G (gas side) ; 1/2"	G (gas side) ; 1/2"	
		inch	L (liquid side) ; 1/4"	L (liquid side) ; 1/4"	
Drain Hose	Inner diameter	mm	12	—	
	Length	m	0.65	—	
Power Cord Length			—	—	
Number of core-wire			—	—	
Dimensions	Height	inch (mm)	11 - 1/32 (280)	29 - 17/32 (750)	
	Width	inch (mm)	31 - 15/32 (799)	34 - 7/16 (875)	
	Depth	inch (mm)	7 - 7/32 (183)	13 - 19/32 (345)	
Net Weight		lb (kg)	20 (9)	106 (48)	
Compressor	Type		—	Involute scroll	
	Motor Type		—	Brushless (4-pole)	
	Rated Output	W	—	700	
Air Circulation	Type		Cross-flow Fan	Propeller Fan	
	Material		ASHT-18	P.P	
	Motor Type		Transistor (8-poles)	Transistor (8-poles)	
	Rate Output	W	30	40	
	Fan Speed	Lo (Cool/Heat)	rpm	980 / 1,160	—
		Me (Cool/Heat)	rpm	1,220 / 1,360	—
Hi (Cool/Heat)		rpm	1,460 / 1,560	660 / 640	
Heat Exchanger	Description		Evaporator	Condenser	
	Tube material		Copper	Copper	
	Fin material		Aluminium (Pre Coat)	Aluminium	
	Fin Type		Slit Fin	Corrugated Fin	
	Row / Stage		(Plate fin configuration, forced draft)		
			2 / 15	1 / 28	
	FPI		21	18	
Size (W x H x L)	mm	610 x 315 x 25.4	871.7 x 711.2 x 22		
Refrigerant Control Device			—	Expansion Valve	
Refrigeration Oil		(c.c)	—	RB68A (360)	
Refrigerant (R410A)		kg (oz)	—	1.06 (37.4)	
Thermostat			Electronic Control	—	
Protection Device			Electronic Control	Electronic Control	
Capillary Tube	Length	mm	—	—	
	Flow Rate	l/min	—	—	
	Inner Diameter	mm	—	—	
Air Filter	Material Style		P.P. Honeycomb	—	

- Specifications are subjected to change without notice for further improvement.

### 3.2. CS-E18DKEW CU-E18DKE

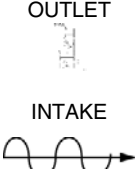
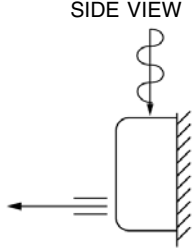
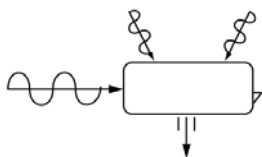
		Unit	CS-E18DKEW	CU-E18DKE
Cooling Capacity		kW kcal/h BTU/h	5.30 (0.90 - 6.00) 4,560 (770 - 5,160) 18,100 (3,070 - 20,500)	
Heating Capacity		kW kcal/h BTU/h	6.60 (0.90 - 8.00) 5,680 (770 - 6,880) 22,500 (3,070 - 27,300)	
Moisture Removal		l/h Pint/h	2.9 (6.1)	
Power Source (Phase, Voltage, Cycle)		ø V Hz	Single 230 50	
Airflow Method		<p>OUTLET</p>  <p>INTAKE</p>	<p>SIDE VIEW</p> 	<p>TOP VIEW</p> 
Air Volume	Lo	m <sup>3</sup> /min (cfm)	Cooling; 12.3 (430) Heating; 13.0 (460)	—
	Me	m <sup>3</sup> /min (cfm)	Cooling; 13.9 (490) Heating; 14.6 (520)	—
	Hi	m <sup>3</sup> /min (cfm)	Cooling; 15.2 (540) Heating; 16.7 (590)	40.0 (1,410)
Noise Level		dB (A)	Cooling; High 44, Low 37 Heating; High 44, Low 37	Cooling; 47 Heating; 47
		Power level dB	Cooling; High 57 Heating; High 57	Cooling; High 60 Heating; High 60
Electrical Data	Input Power	W	Cooling; 1,650 (215 - 2,050) Heating; 1,790 (245 - 2,650)	
	Running Current	A	Cooling; 7.5 Heating; 8.1	
	EER	W/W	Cooling; 3.21 (4.19 - 2.93)	
		BTU/hW	Cooling; 11.0 (14.3 - 10.0)	
	COP	W/W	Heating; 3.69 (3.67 - 3.02)	
BTU/hW		Heating; 12.6 (12.5 - 10.3)		
Starting Current	A	8.3		
Piping Connection Port (Flare piping)		inch inch	G ; Half Union 1/2" L ; Half Union 1/4"	G ; 3-way valve 1/2" L ; 2-way valve 1/4"

		Unit	CS-E18DKEW	CU-E18DKE	
Pipe Size (Flare piping)		inch inch	G (gas side) ; 1/2" L (liquid side) ; 1/4"	G (gas side) ; 1/2" L (liquid side) ; 1/4"	
Drain Hose	Inner diameter	mm	12	—	
	Length	m	0.65	—	
Power Cord Length			—	—	
Number of core-wire			—	—	
Dimensions	Height	inch (mm)	10 - 13/16 (275)	29 - 17/32 (750)	
	Width	inch (mm)	39 - 9/32 (998)	34 - 7/16 (875)	
	Depth	inch (mm)	9 - 1/16 (230)	13 - 19/32 (345)	
Net Weight		lb (kg)	24 (11)	108 (49)	
Compressor	Type		—	Involute scroll	
	Motor Type		—	Brushless (4-pole)	
	Rated Output	W	—	900	
Air Circulation	Type		Cross-flow Fan	Propeller Fan	
	Material		ASHT-18	P.P	
	Motor Type		Transistor (8-poles)	Transistor (8-poles)	
	Rate Output	W	30	40	
	Fan Speed	Lo (Cool/Heat)	rpm	1,170 / 1,240	—
		Me (Cool/Heat)	rpm	1,330 / 1,395	—
Hi (Cool/Heat)		rpm	1,450 / 1,580	660 / 640	
Heat Exchanger	Description		Evaporator	Condenser	
	Tube material		Copper	Copper	
	Fin material		Aluminium (Pre Coat)	Aluminium	
	Fin Type		Slit Fin	Corrugated Fin	
	Row / Stage		(Plate fin configuration, forced draft) 2 / 15	2 / 34	
	FPI		21	16	
	Size (W × H × L)	mm	810 × 315 × 25.4	849.3 × 714 × 36.4 878	
Refrigerant Control Device			—	Expansion Valve	
Refrigeration Oil		(c.c)	—	RB68A (360)	
Refrigerant (R410A)		kg (oz)	—	1.18 (41.7)	
Thermostat			Electronic Control	—	
Protection Device			Electronic Control	Electronic Control	
Capillary Tube	Length	mm	—	—	
	Flow Rate	l/min	—	—	
	Inner Diameter	mm	—	—	
Air Filter	Material Style		P.P. Honeycomb	—	

- Specifications are subjected to change without notice for further improvement.

### 3.3. CS-E21DKES CU-E21DKE

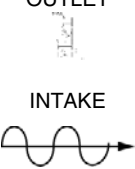
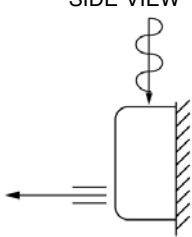
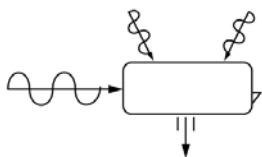
		Unit	CS-E21DKES	CU-E21DKE
Cooling Capacity		kW kcal/h BTU/h	6.30 (0.90 - 7.10) 5,420 (770 - 6,110) 21,500 (3,070 - 24,200)	
Heating Capacity		kW kcal/h BTU/h	7.20 (0.90 - 8.50) 6,190 (770 - 7,310) 24,600 (3,070 - 29,000)	
Moisture Removal		l/h Pint/h	3.5 (7.4)	
Power Source (Phase, Voltage, Cycle)		ø V Hz	Single 230 50	
Airflow Method		<p>OUTLET</p>  <p>INTAKE</p>	<p>SIDE VIEW</p> 	<p>TOP VIEW</p> 
Air Volume	Lo	m <sup>3</sup> /min (cfm)	Cooling; 12.5 (440) Heating; 13.5 (480)	—
	Me	m <sup>3</sup> /min (cfm)	Cooling; 14.4 (510) Heating; 14.9 (530)	—
	Hi	m <sup>3</sup> /min (cfm)	Cooling; 16.2 (570) Heating; 17.3 (610)	Cooling; 42.8 (1,510) Heating; 41.5 (1,460)
Noise Level		dB (A)	Cooling; High 45, Low 37 Heating; High 45, Low 37	Cooling; 48 Heating; 49
		Power level dB	Cooling; High 58 Heating; High 58	Cooling; High 61 Heating; High 62
Electrical Data	Input Power	W	Cooling; 2,210 (215 - 2,540) Heating; 2,100 (245 - 2,750)	
	Running Current	A	Cooling; 9.9 Heating; 9.3	
	EER	W/W	Cooling; 2.85 (4.19 - 2.80)	
		BTU/hW	Cooling; 9.7 (14.3 - 9.5)	
	COP	W/W	Heating; 3.43 (3.67 - 3.09)	
		BTU/hW	Heating; 11.7 (12.5 - 10.5)	
Starting Current	A	9.7		
Piping Connection Port (Flare piping)		inch inch	G ; Half Union 1/2" L ; Half Union 1/4"	G ; 3-way valve 1/2" L ; 2-way valve 1/4"

		Unit	CS-E21DKES	CU-E21DKE	
Pipe Size (Flare piping)		inch inch	G (gas side) ; 1/2" L (liquid side) ; 1/4"	G (gas side) ; 1/2" L (liquid side) ; 1/4"	
Drain Hose	Inner diameter	mm	12	—	
	Length	m	0.65	—	
Power Cord Length			—	—	
Number of core-wire			—	—	
Dimensions	Height	inch (mm)	10 - 13/16 (275)	29 - 17/32 (750)	
	Width	inch (mm)	39 - 9/32 (998)	34 - 7/16 (875)	
	Depth	inch (mm)	9 - 1/16 (230)	13 - 19/32 (345)	
Net Weight		lb (kg)	24 (11)	112 (51)	
Compressor	Type		—	Involute scroll	
	Motor Type		—	Brushless (4-pole)	
	Rated Output	W	—	900	
Air Circulation	Type		Cross-flow Fan	Propeller Fan	
	Material		ASHT-18	P.P	
	Motor Type		Transistor (8-poles)	Transistor (8-poles)	
	Rate Output	W	30	40	
	Fan Speed	Lo (Cool/Heat)	rpm	1,170 / 1,270	—
		Me (Cool/Heat)	rpm	1,355 / 1,400	—
Hi (Cool/Heat)		rpm	1,520 / 1,610	700 / 680	
Heat Exchanger	Description		Evaporator	Condenser	
	Tube material		Copper	Copper	
	Fin material		Aluminium (Pre Coat)	Aluminium	
	Fin Type		Slit Fin	Corrugated Fin	
	Row / Stage		(Plate fin configuration, forced draft) 2 / 15	2 / 34	
	FPI		19	18	
	Size (W × H × L)	mm	810 × 315 × 25.4	839.5 × 714 × 36.4 868	
Refrigerant Control Device			—	Expansion Valve	
Refrigeration Oil		(c.c)	—	RB68A (360)	
Refrigerant (R410A)		kg (oz)	—	1.29 (45.5)	
Thermostat			Electronic Control	—	
Protection Device			Electronic Control	Electronic Control	
Capillary Tube	Length	mm	—	—	
	Flow Rate	l/min	—	—	
	Inner Diameter	mm	—	—	
Air Filter	Material		P.P.	—	
	Style		Honeycomb	—	

- Specifications are subjected to change without notice for further improvement.

## 4 Dimensions

### 4.1. Indoor Unit & Remote Control

#### 4.1.1. CS-E15DKEW

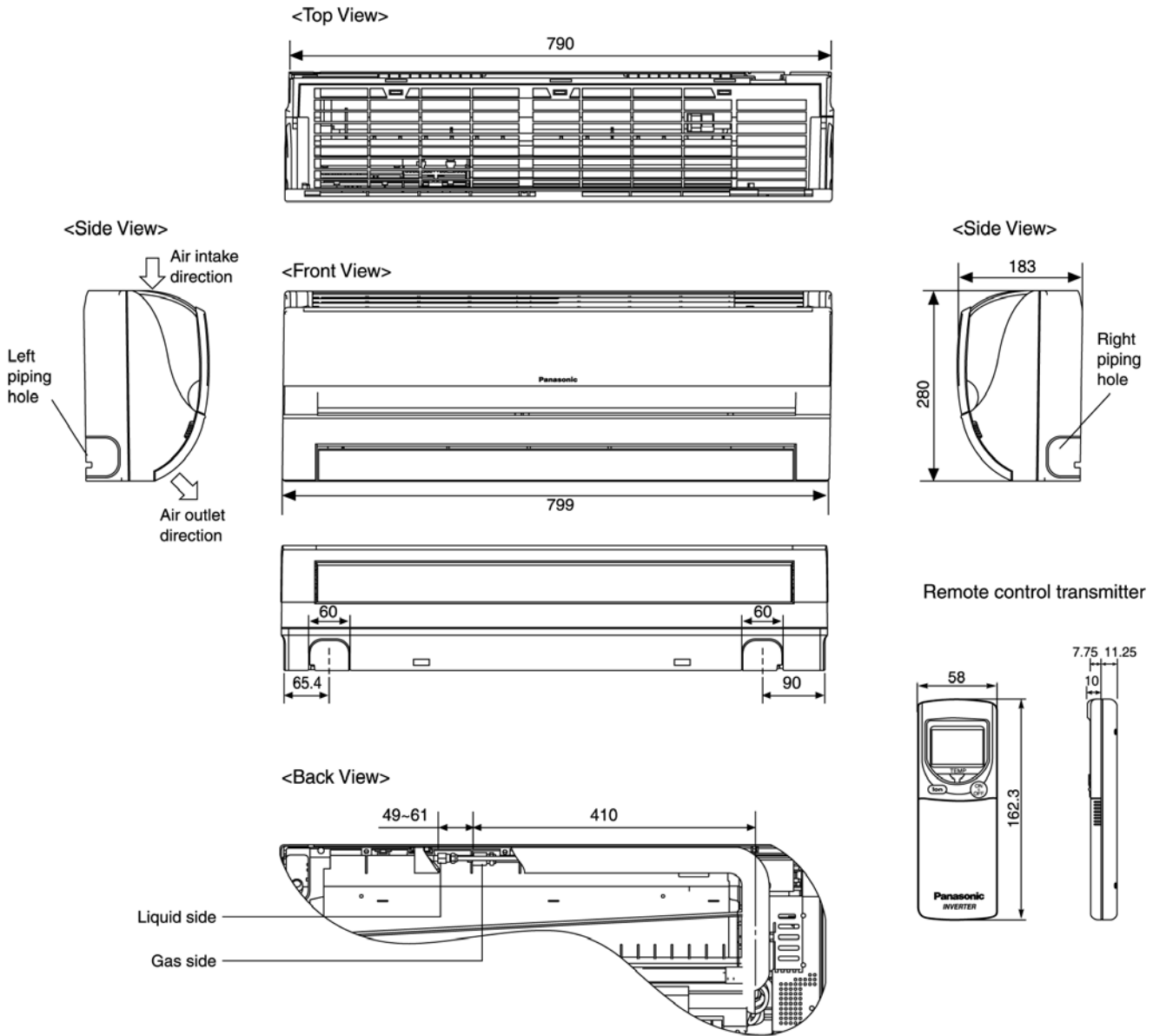

Relative position between the indoor unit and the installation plate <Front View>

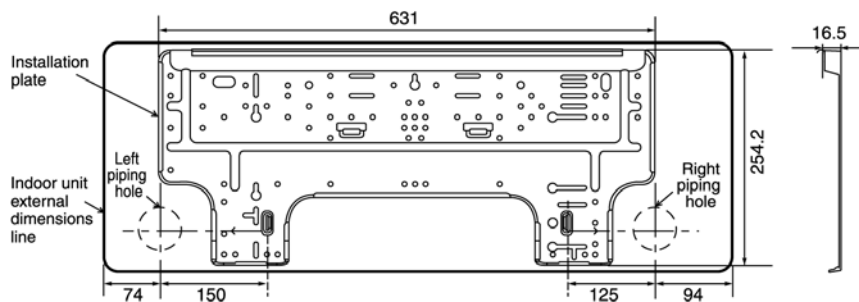

Unit : mm



### 4.1.2. CS-E18DKEW CS-E21DKES

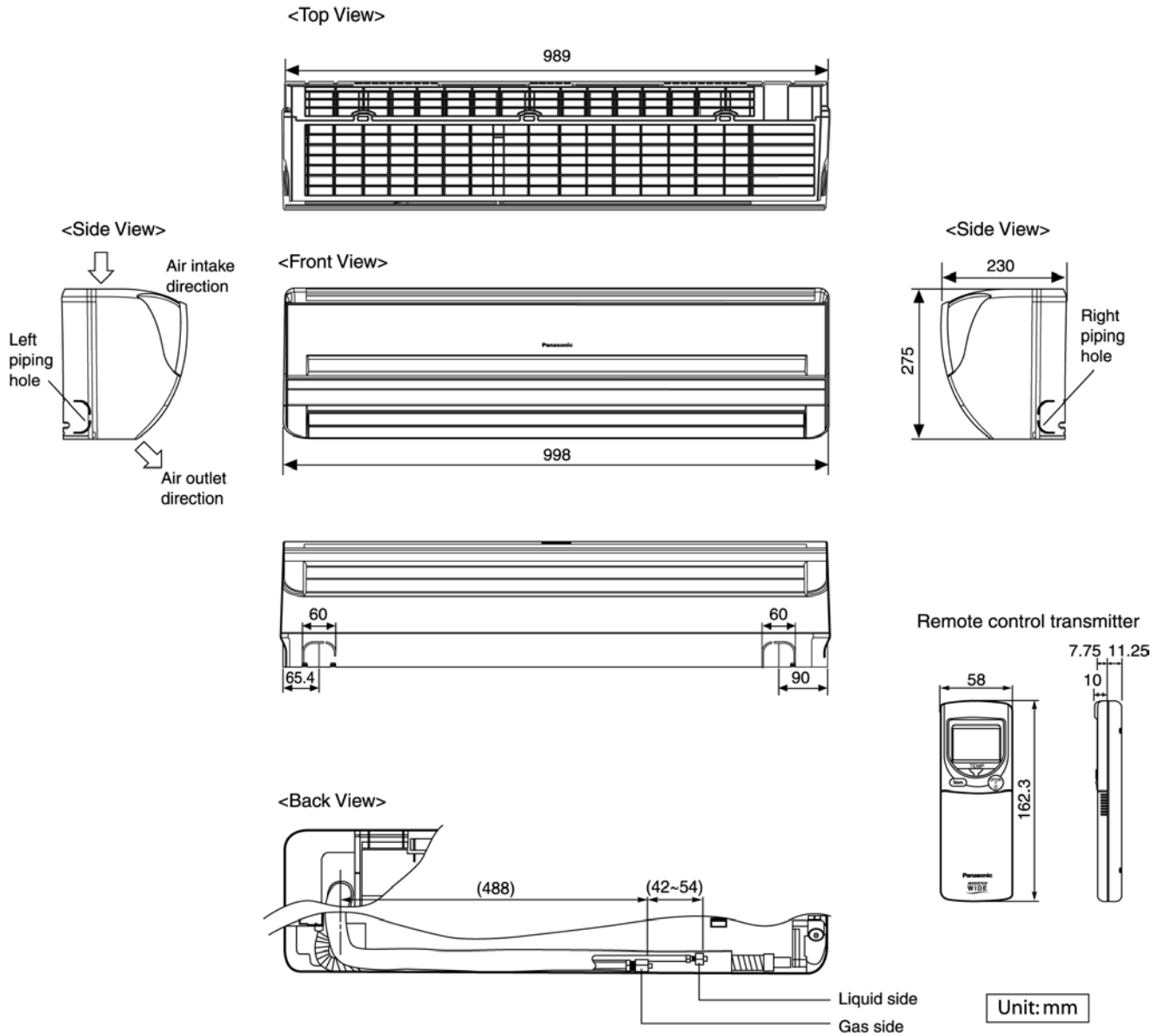

Relative position between the indoor unit and the installation plate <Front View>

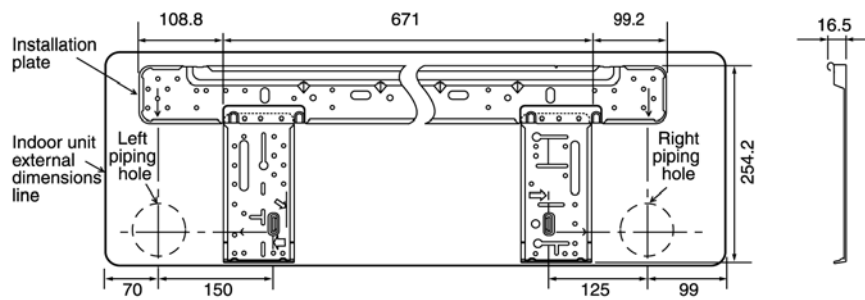

## 4.2. Outdoor Unit

### 4.2.1. CU-E15DKE CU-E18DKE CU-E21DKE

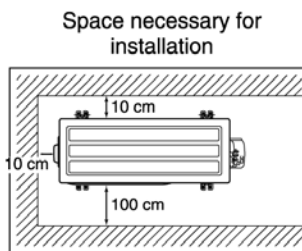

Anchor Bolt Pitch  
383 x 612.5

<Top View>

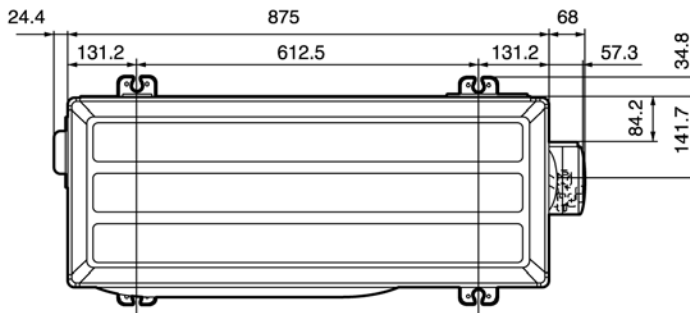

<Side View>

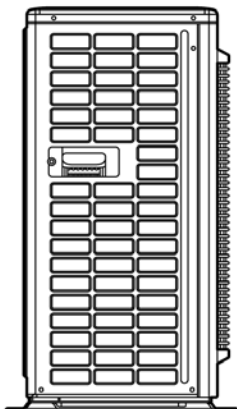

<Front View>

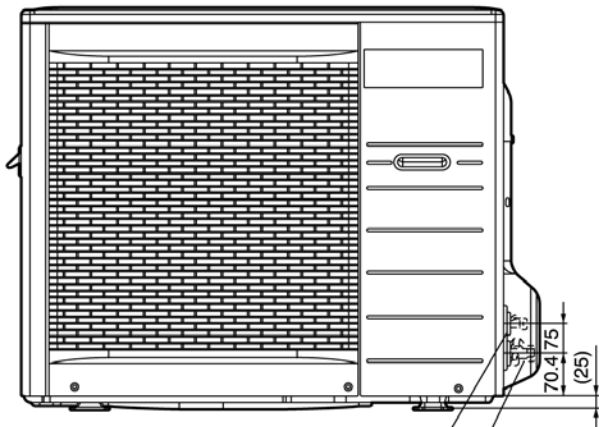

<Side View>

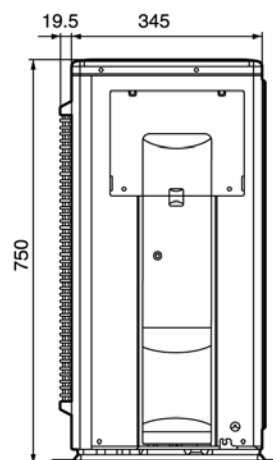

3-way valve at Gas side  
(Low Pressure)

2-way valve at Liquid side  
(High Pressure)

Unit: mm

# 5 Refrigeration Cycle Diagram

CS-E15DKEW CU-E15DKE  
 CS-E18DKEW CU-E18DKE  
 CS-E21DKES CU-E21DKE

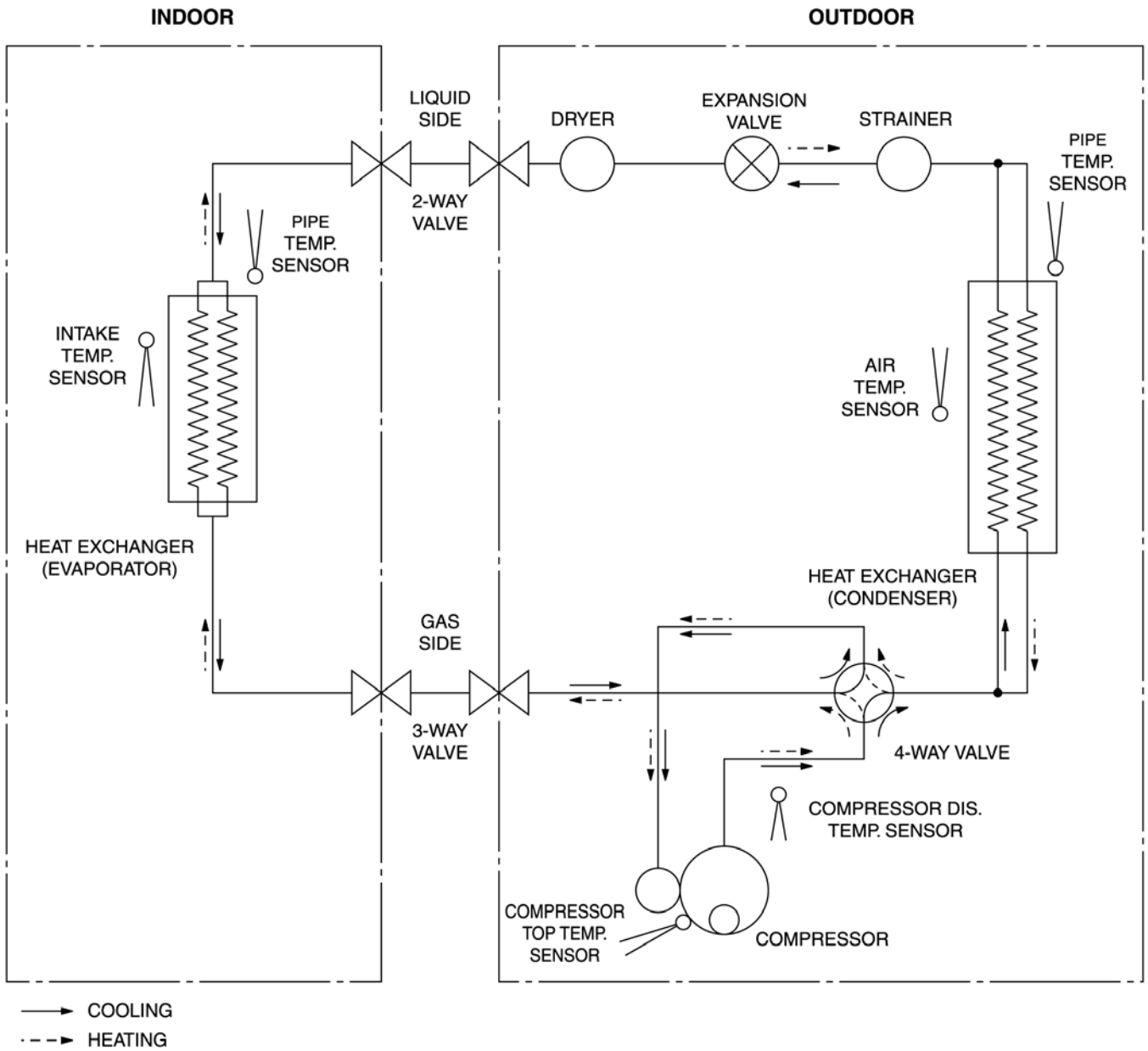

Model	Piping size		Rated Length (m)	Common Length (m)	Max. Elevation (m)	Max. Piping Length (m)	Additional Refrigerant (g/m)
	Gas	Liquid					
E15DK	1/2"	1/4"	7.5	7.5	5	15	20
E18DK, E21DK	1/2"	1/4"	5	10	15	20	20

※ If piping length is over common length, additional refrigerant should be added as shown in the table.

# 6 Block Diagram

CS-E15DKEW CU-E15DKE  
 CS-E18DKEW CU-E18DKE  
 CS-E21DKES CU-E21DKE

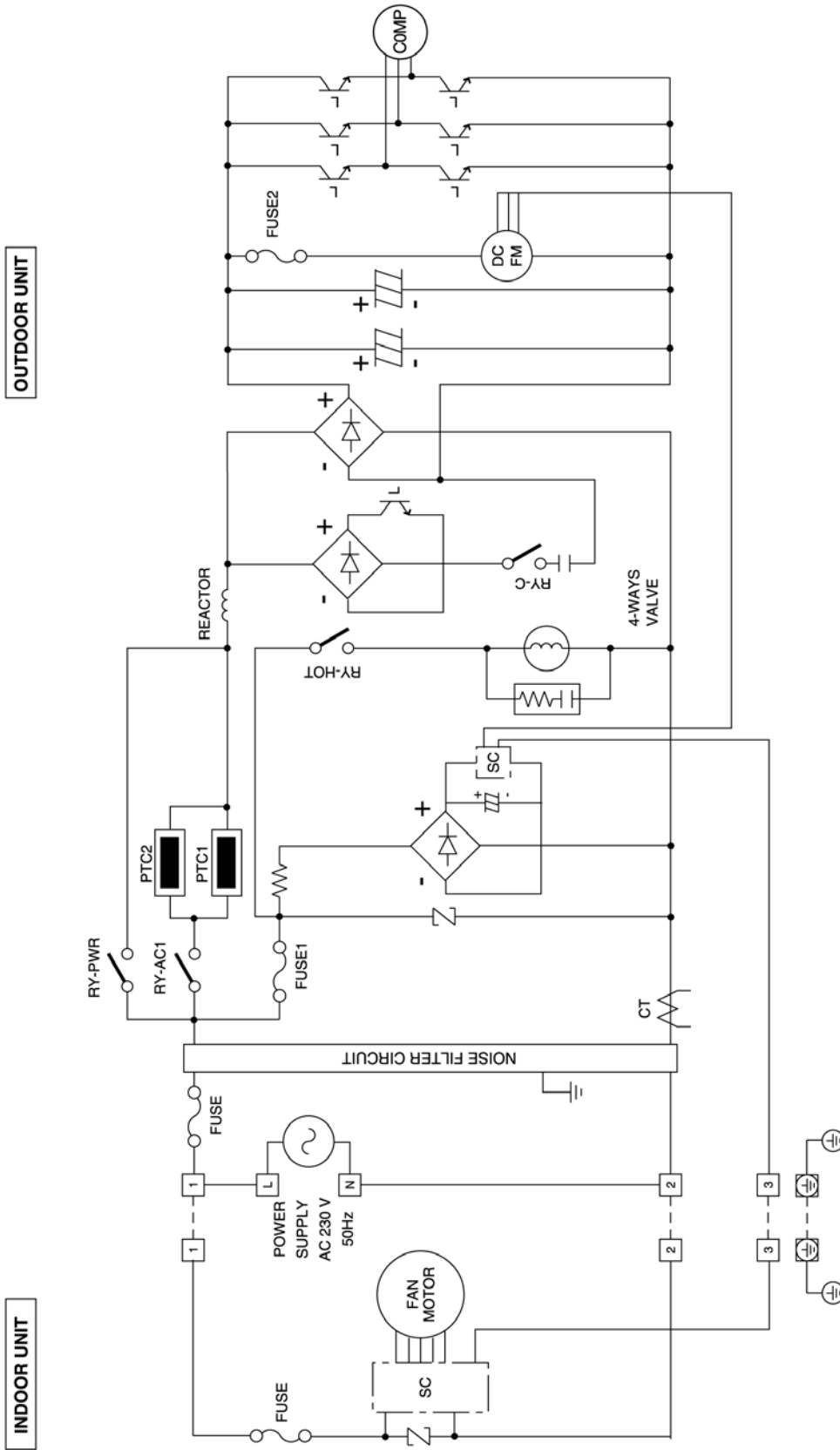

※ [ ] Indicates the electronic control unit.

# 7 Wiring Diagram

**CS-E15DKEW CU-E15DKE**  
**CS-E18DKEW CU-E18DKE**  
**CS-E21DKES CU-E21DKE**

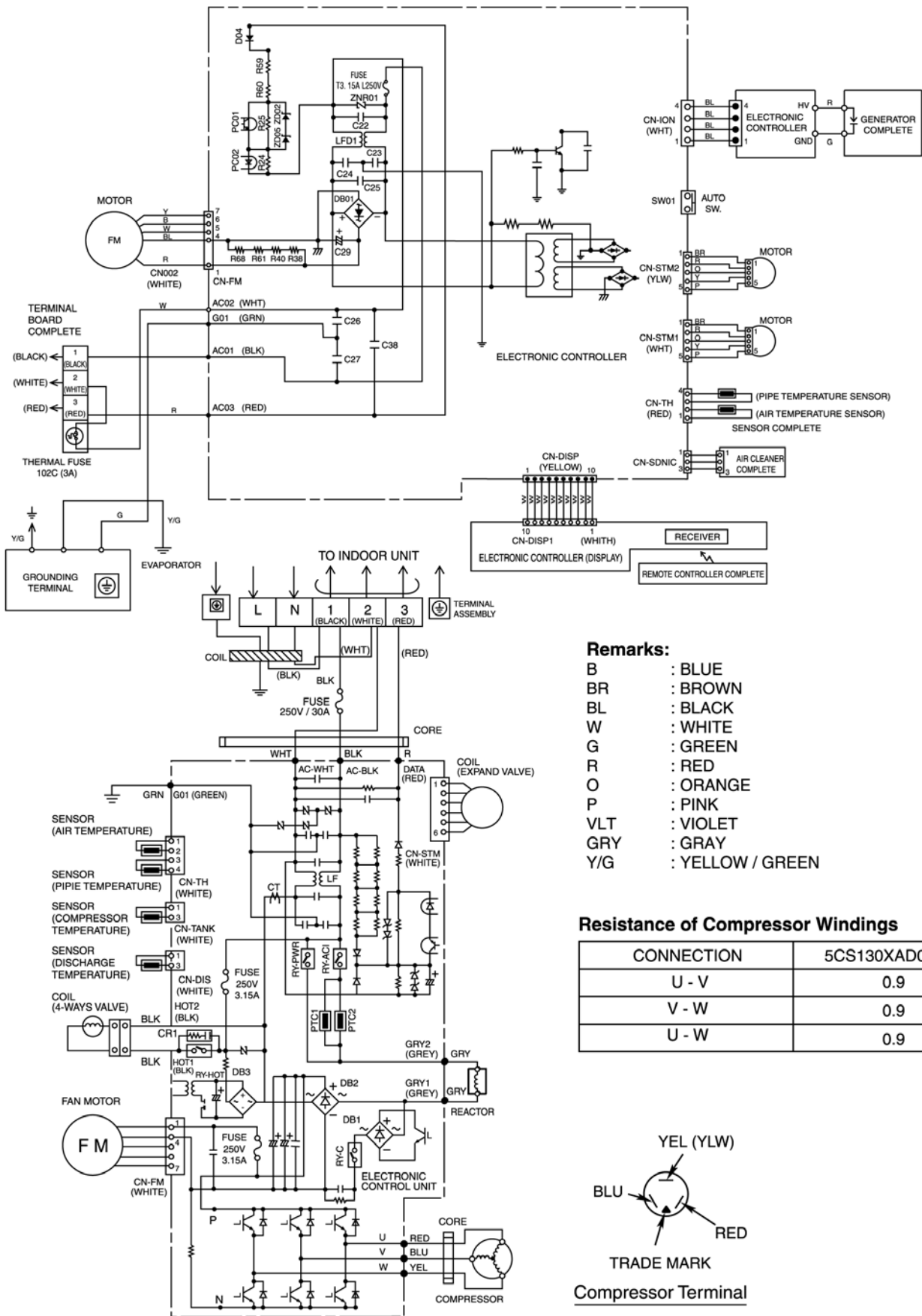







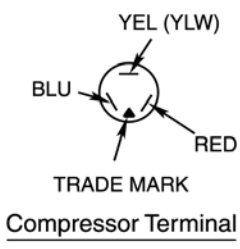

- Remarks:**
- B : BLUE
  - BR : BROWN
  - BL : BLACK
  - W : WHITE
  - G : GREEN
  - R : RED
  - O : ORANGE
  - P : PINK
  - VLT : VIOLET
  - GRY : GRAY
  - Y/G : YELLOW / GREEN

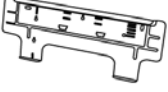
**Resistance of Compressor Windings**

CONNECTION	5CS130XD04 (Ω)
U - V	0.9
V - W	0.9
U - W	0.9



### Attached accessories

No.	Accessories part	Qty.	No.	Accessories part	Qty.
1	Installation plate 	1	5	Remote Control holder 	1
2	Installation plate fixing screw 	6	6	Remote Control holder fixing screw 	2
3	Remote control 	1	7	Super alleru-buster filter 	1
4	Battery 	2	8	Drain elbow 	1

Applicable piping kit  
CZ-4F5, 7, 10BP (E15DK)

### Select the best location

#### INDOOR UNIT

- There should not be any heat source or steam near the unit.
- There should not be any obstacles blocking the air circulation.
- A place where air circulation in the room is good.
- A place where drainage can be easily done.
- A place where noise prevention is taken into consideration.
- Do not install the unit near the door way.
- Ensure the spaces indicated by arrows from the wall, ceiling, fence or other obstacles.
- Recommended installation height for indoor unit shall be at least 2.5 m.

#### OUTDOOR UNIT

- If an awning is built over the unit to prevent direct sunlight or rain, be careful that heat radiation from the condenser is not obstructed.
- There should not be any animal or plant which could be affected by hot air discharged.
- Keep the spaces indicated by arrows from wall, ceiling, fence or other obstacles.
- Do not place any obstacles which may cause a short circuit of the discharged air.
- If piping length is over 7.5 m, additional refrigerant should be added as shown in the table.

Model	Piping size		Rated Length (m)	Max. Elevation (m)	Max. Piping Length (m)	Additional Refrigerant (g/m)
	Gas	Liquid				
E15DK	1/2"	1/4"	7.5	5	15	20

### Indoor/Outdoor Unit Installation Diagram

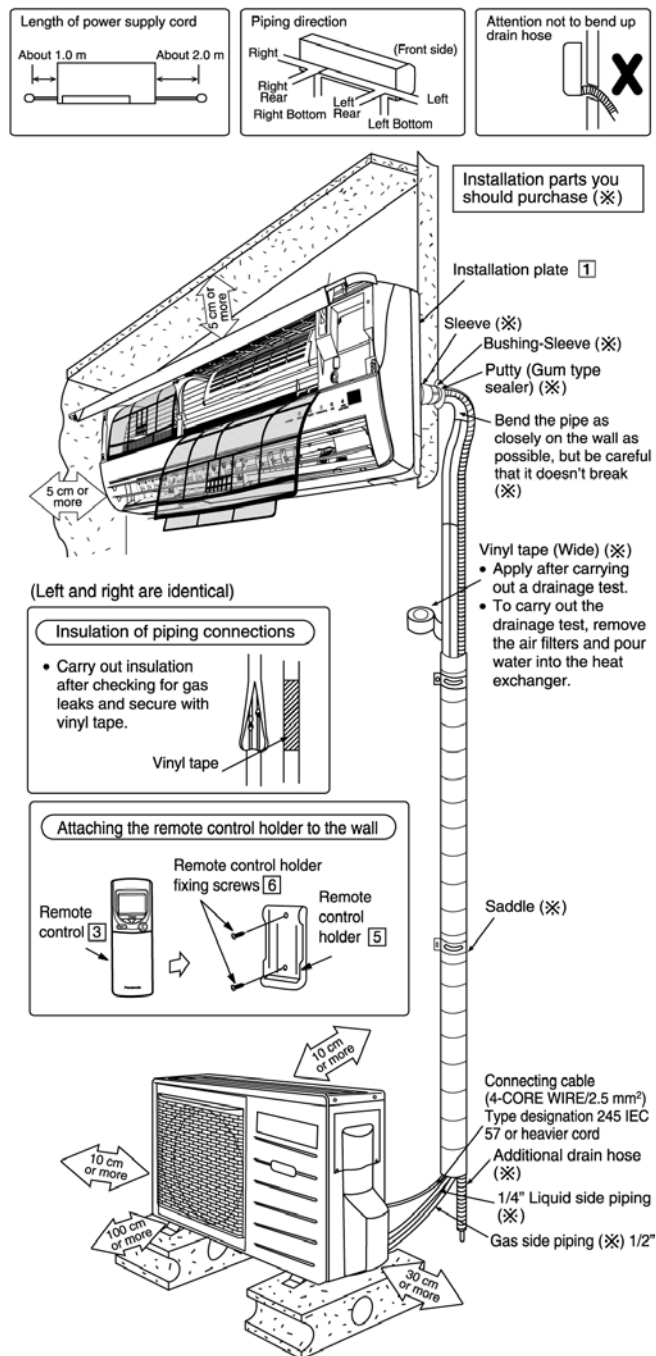

- This illustration is for explanation purposes only. The indoor unit will actually face a different way.

**Attached accessories**

No.	Accessories part	Qty.	No.	Accessories part	Qty.
1	Installation plate	1	5	Remote Control holder	1
2	Installation plate fixing screw	6	6	Remote Control holder fixing screw	2
3	Remote control	1	7	Super alleru-buster filter	1
4	Battery	2	8	Drain elbow	1

Applicable piping kit  
CZ-4F5, 7, 10BP (E18DK, E21DK)

**Select the best location**

**INDOOR UNIT**

- There should not be any heat source or steam near the unit.
- There should not be any obstacles blocking the air circulation.
- A place where air circulation in the room is good.
- A place where drainage can be easily done.
- A place where noise prevention is taken into consideration.
- Do not install the unit near the door way.
- Ensure the spaces indicated by arrows from the wall, ceiling, fence or other obstacles.
- Recommended installation height for indoor unit shall be at least 2.5 m.

**OUTDOOR UNIT**

- If an awning is built over the unit to prevent direct sunlight or rain, be careful that heat radiation from the condenser is not obstructed.
- There should not be any animal or plant which could be affected by hot air discharged.
- Keep the spaces indicated by arrows from wall, ceiling, fence or other obstacles.
- Do not place any obstacles which may cause a short circuit of the discharged air.
- If piping length is over 10 m, additional refrigerant should be added as shown in the table.

Model	Piping size		Rated Length (m)	Max. Elevation (m)	Max. Piping Length (m)	Additional Refrigerant (g/m)
	Gas	Liquid				
E18DK, E21DK	1/2"	1/4"	5	15	20	20

**Indoor/Outdoor Unit Installation Diagram**

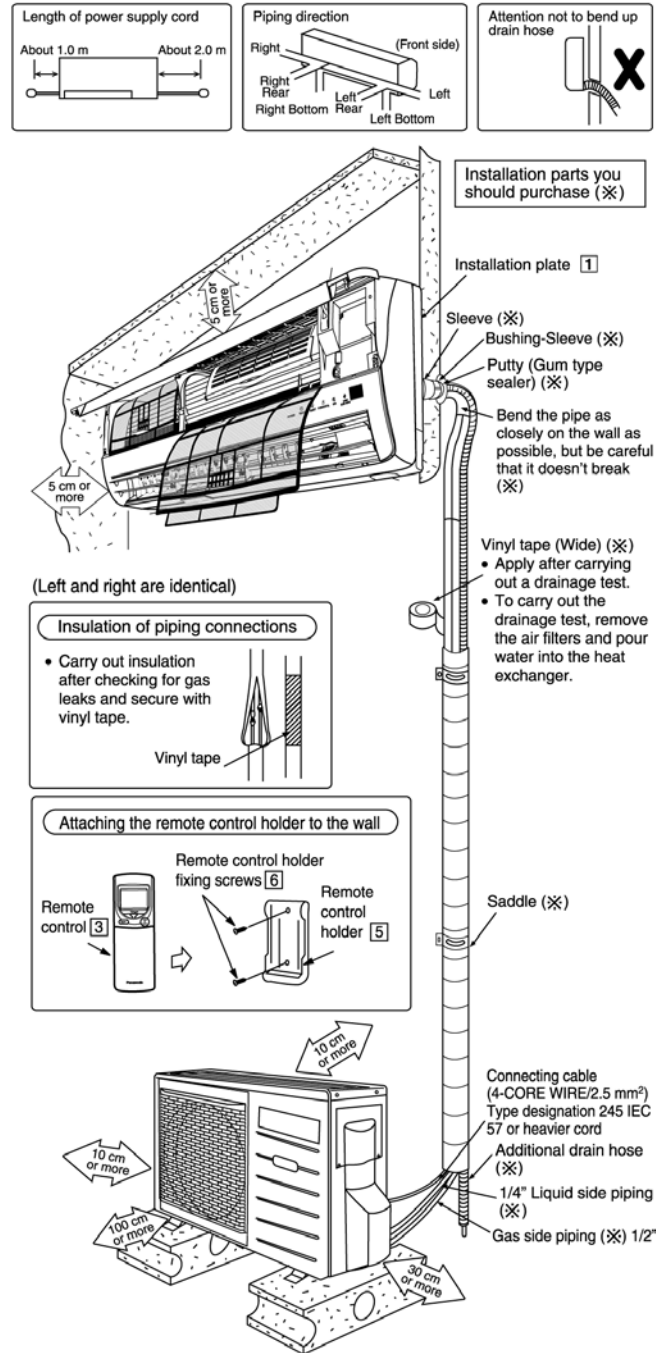

- This illustration is for explanation purposes only. The indoor unit will actually face a different way.

# 13 Servicing Information

## Caution:

- Pb free solder has a higher melting point than standard solder; Typically the melting point is 50 - 70°F (30 - 40°C) higher. Please use a high temperature soldering iron. In case of the soldering iron with temperature control, please set it to 700 ± 20°F (370 ± 10°C).
- Pb free solder will tend to splash when heated too high (about 1100° F/600°C).

## 13.1. Troubleshooting

### 1. Rated Frequency Operation

During troubleshooting and servicing, rated compressor operating frequency must be obtained in order to check the specification and technical data. Below are the methods used to obtain rated compressor operating specification.

#### (a) Cooling

- Press the Auto button continuously for 5 seconds or less than 8 seconds, the air conditioner starts operation at Cooling rated frequency. ("beep" will be heard at the 5th second.)

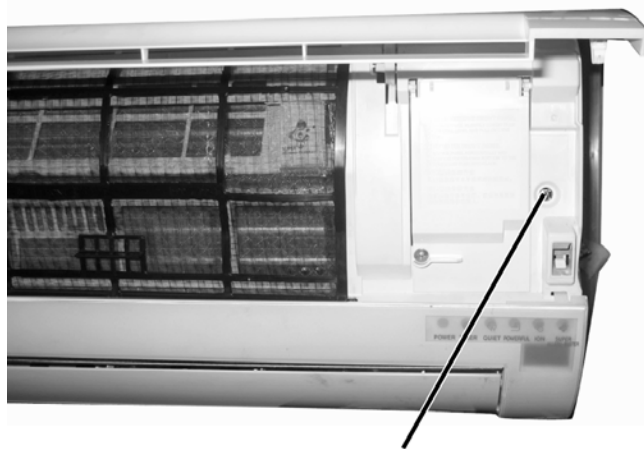

Automatic Operation Switch

- Short the service terminal (CN-S) of the outdoor printed circuit board. The operation of air conditioner is Cooling rated frequency.

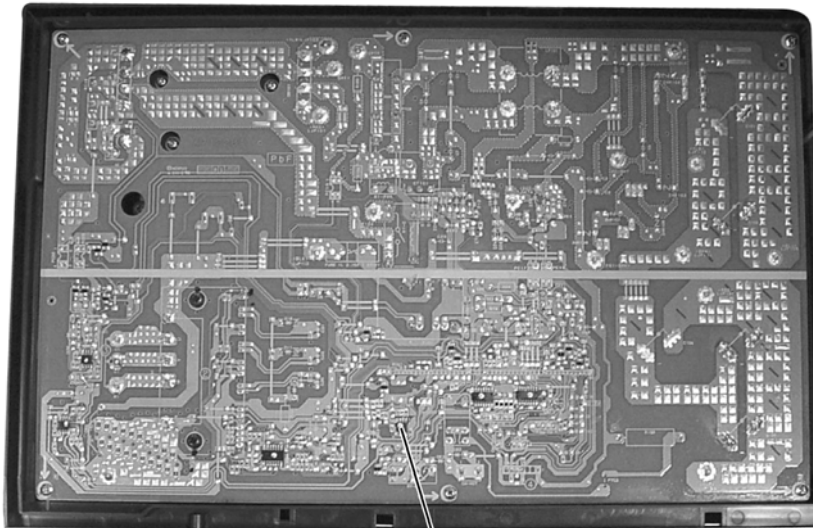

CN-S

#### (b) Heating

Press the Auto button continuously for 8 seconds or less than 11 seconds, the air conditioner starts operation at Heating rated frequency. ("beep" "beep" will be heard at the 8th second.)



**2. Troubleshooting Air Conditioner**

**Refrigeration cycle system**

In order to diagnose malfunctions, make sure that there are no electrical problems before inspecting the refrigeration cycle. Such problems include insufficient insulation, problem with the power source, malfunction of a compressor and a fan.

The normal outlet air temperature and pressure of the refrigeration cycle depends on various conditions, the standard values for them are shown in the table to the right.

Normal Pressure and Outlet Air Temperature (Standard)

	Gas pressure MPa (kg/cm <sup>2</sup> G)	Outlet air temperature (°C)
Cooling Mode	0.9 ~ 1.2 (9 ~ 12)	12 ~ 16
Heating Mode	2.3 ~ 2.9 (23 ~ 29)	36 ~ 45

- ★ Condition:
- Indoor fan speed; High
  - Outdoor temperature 35°C at cooling mode and 7°C at heating mode.
  - Compressor operates at rated frequency

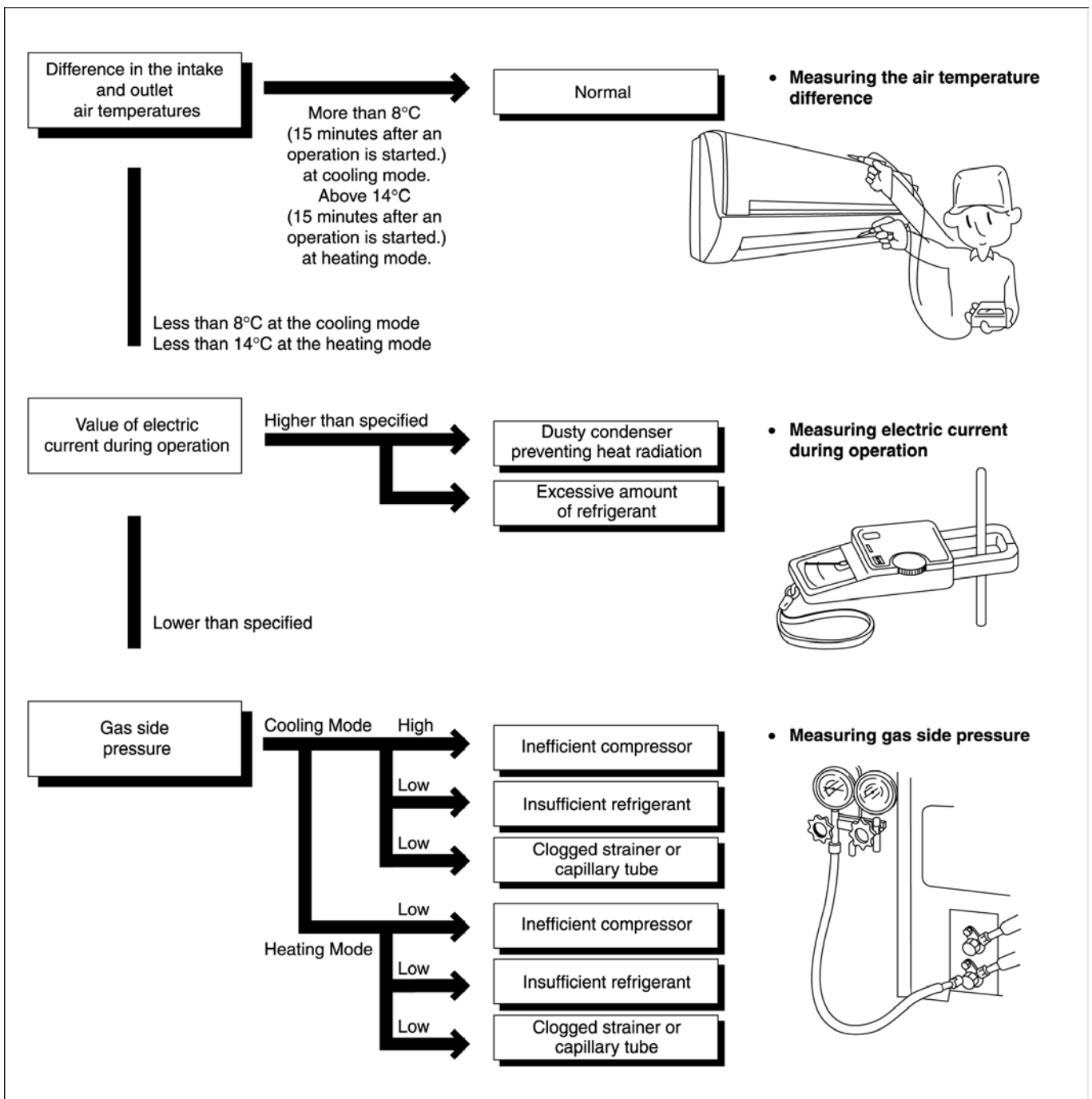

### 1. Relationship between the condition of the air conditioner and pressure and electric current

Condition of the air conditioner	Cooling Mode			Heating Mode		
	Low Pressure	High Pressure	Electric current during operation	Low Pressure	High Pressure	Electric current during operation
Insufficient refrigerant (gas leakage)	↘	↘	↘	↘	↘	↘
Clogged capillary tube or Strainer	↘	↘	↘	↗	↗	↗
Short circuit in the indoor unit	↘	↘	↘	↗	↗	↗
Heat radiation deficiency of the outdoor unit	↗	↗	↗	↘	↘	↘
Inefficient compression	↗	↘	↘	↗	↘	↘

- Carry on the measurements of pressure, electric current, and temperature fifteen minutes after an operation is started.

## 13.2. Breakdown Self Diagnosis Function

Once abnormality detected during operation, the unit will immediately stop its operation (Timer LED is blinking) and maximum of three error codes (abnormality) will be saved in memory. The abnormality of the operation can be identified through the below breakdown diagnosis method:

- Press "CHECK" button at remote control continuously for more than five seconds to turn on the diagnosis mode, "H11" will be displayed at remote control.
- By pressing the TIMER "Λ" button once, next error code will be displayed; press "V" button once, previous error code will be displayed.
- If error code displayed matches the error code saved in unit memory (abnormality detected), "beep, beep, beep...." sounds will be heard for 4 seconds and Power LED will light on. Otherwise, one "beep" sound is heard.

If "CHECK" button is press again or without any operation for 30 seconds, the diagnosis mode will turn off.

Error Codes Table

Diagnosis display	Abnormality / Protection control	Abnormality Judgement	Emergency operation	Primary location to verify
H11	Indoor / outdoor abnormal communication	> 1 min after starting operation	Indoor fan operation only	<ul style="list-style-type: none"> <li>• Internal / external cable connections</li> <li>• Indoor / Outdoor PCB</li> </ul>
H12	Connection capability rank abnormal	—	—	—
H14	Indoor intake air temperature sensor abnormality	Continue for 5 sec.	—	<ul style="list-style-type: none"> <li>• Intake air temperature sensor (defective or disconnected)</li> </ul>
H15	Outdoor compressor temperature sensor abnormality	Continue for 5 sec.	—	<ul style="list-style-type: none"> <li>• Compressor temperature sensor (defective or disconnected)</li> </ul>
H16	Outdoor Current Transformer open circuit	—	—	<ul style="list-style-type: none"> <li>• Outdoor PCB</li> <li>• IPM (Power transistor) module</li> </ul>
H19	Indoor fan motor mechanism lock	—	—	<ul style="list-style-type: none"> <li>• Indoor PCB</li> <li>• Fan motor</li> </ul>
H23	Indoor heat exchanger temperature sensor abnormality	Continue for 5 sec.	O (Cooling only)	<ul style="list-style-type: none"> <li>• Heat exchanger temperature sensor (defective or disconnected)</li> </ul>
H26	Ion abnormality	—	—	<ul style="list-style-type: none"> <li>• Indoor PCB</li> <li>• Ionizer</li> </ul>
H27	Outdoor air temperature sensor abnormality	Continue for 5 sec.	O	<ul style="list-style-type: none"> <li>• Outdoor temperature sensor (defective or disconnected)</li> </ul>
H28	Outdoor heat exchanger temperature sensor abnormality	Continue for 5 sec.	O	<ul style="list-style-type: none"> <li>• Outdoor heat exchanger temperature sensor (defective or disconnected)</li> </ul>
H30	Discharge temperature sensor abnormality	Continue for 5 sec.	—	<ul style="list-style-type: none"> <li>• Discharge temperature sensor</li> </ul>
H33	Indoor/Outdoor wrong connection	—	—	<ul style="list-style-type: none"> <li>• Indoor/Outdoor supply voltage</li> </ul>
H38	Indoor/Outdoor mismatch (brand code)	—	—	—
H97	Outdoor Fan Motor lock abnormality	—	—	<ul style="list-style-type: none"> <li>• Outdoor PCB</li> <li>• Outdoor Fan Motor</li> </ul>
H98	Indoor high pressure protection	—	—	<ul style="list-style-type: none"> <li>• Air filter dirty</li> <li>• Air circulation short circuit</li> </ul>
H99	Indoor heat exchanger anti-freezing protection	—	—	<ul style="list-style-type: none"> <li>• Insufficient refrigerant</li> <li>• Air filter dirty</li> </ul>
F11	Cooling / Heating cycle changeover abnormality	4 times occurrence within 30 minutes	—	<ul style="list-style-type: none"> <li>• 4-way valve</li> <li>• V-coil</li> </ul>
F90	PFC control	4 times occurrence within 10 minutes	—	<ul style="list-style-type: none"> <li>• Voltage at PFC</li> </ul>
F91	Refrigeration cycle abnormality	7 times occurrence continuously	—	<ul style="list-style-type: none"> <li>• No refrigerant (3-way valve is closed)</li> </ul>
F93	Outdoor compressor abnormal revolution	4 times occurrence within 20 minutes	—	<ul style="list-style-type: none"> <li>• Outdoor compressor</li> </ul>
F95	Cool high pressure protection	4 times occurrence within 20 minutes	—	<ul style="list-style-type: none"> <li>• Outdoor refrigerant circuit</li> </ul>
F96	IPM (power transistor) overheating protection	—	—	<ul style="list-style-type: none"> <li>• Excess refrigerant</li> <li>• Improper heat radiation</li> <li>• IPM (Power transistor)</li> </ul>
F97	Outdoor compressor overheating protection	4 times occurrence within 20 minutes	—	<ul style="list-style-type: none"> <li>• Insufficient refrigerant</li> <li>• Compressor</li> </ul>
F98	Total running current protection	3 times occurrence within 20 minutes	—	<ul style="list-style-type: none"> <li>• Excess refrigerant</li> <li>• Improper heat radiation</li> </ul>
F99	Outdoor Direct Current (DC) peak detection	7 times occurrence continuously	—	<ul style="list-style-type: none"> <li>• Outdoor PCB</li> <li>• IPM (Power transistor)</li> <li>• Compressor</li> </ul>

Note:

“O” - Frequency measured and fan speed fixed.

The memory data of error code is erased when the power supply is cut off, or press the Auto Switch until “beep” sound heard following by pressing the “RESET” button at Remote Control.

Although operation forced to stop when abnormality detected, emergency operation is possible for certain errors (refer to Error Codes Table) by using Remote Control or Auto Switch at indoor unit. However, the Remote Control signal receiving sound is changed from one “beep” to four “beep” sounds.

### 13.3. Remote Control

• **Remote Control Reset**

When the batteries are inserted for the first time, or the batteries are replaced, all the indications will blink and the remote control might not work.

If this happen, remove the cover of the remote control and push the reset point once to clear the memory data.

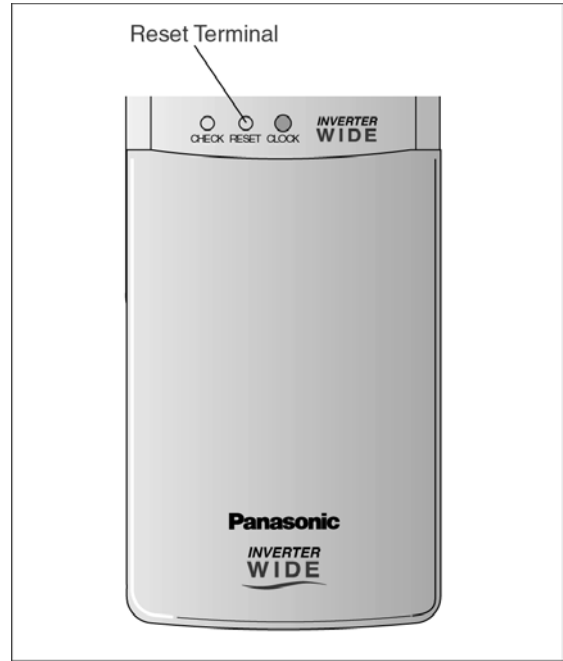

• **Changing the wireless remote control transmission code**

When there are more than one indoor units installed in the same room, it is possible to set different remote control receiving signal by modifying the jumpers inside Remote Control.

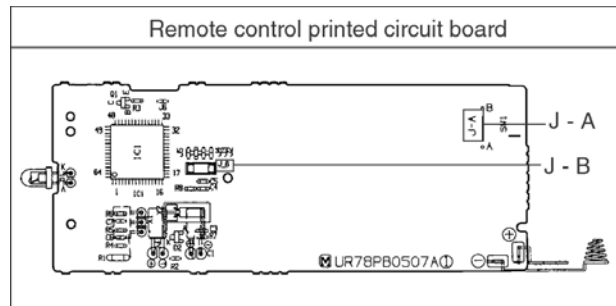

	Remote control printed circuit board		Note
	J - A	J - B	
0	SHORT	OPEN	At product delivery
1	OPEN	OPEN	
2	SHORT	SHORT	
3	OPEN	SHORT	

# 1 Technical Data (Page: 100)

## 1.1. Operation Characteristics

### 1.1.1. CS-E15DKEW CU-E15DKE

#### • Cooling Characteristic

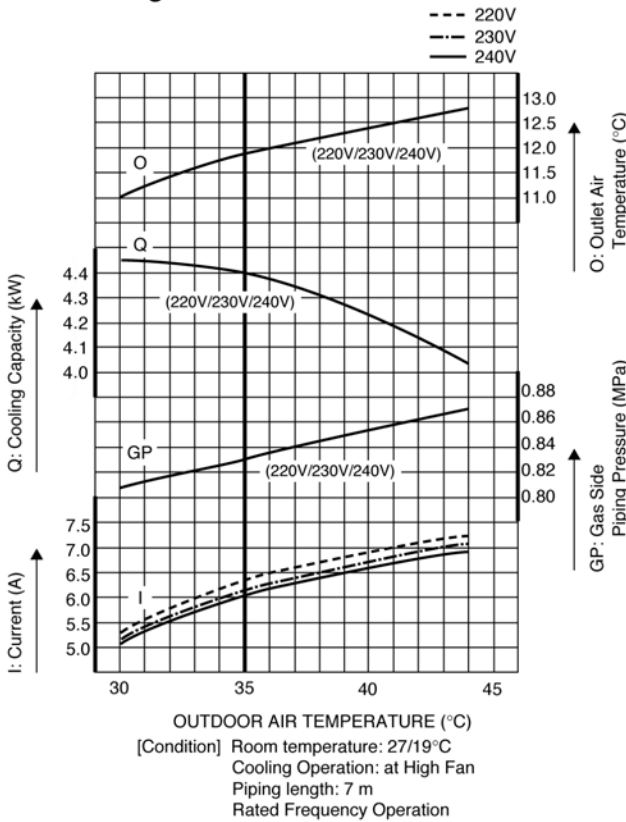

#### • Piping Length Characteristic (Cooling)

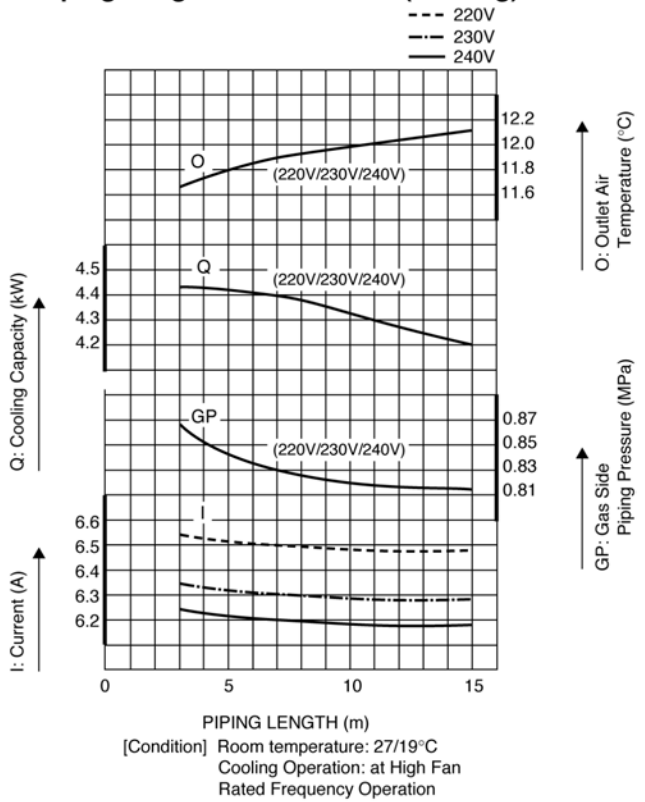

#### • Heating Characteristic

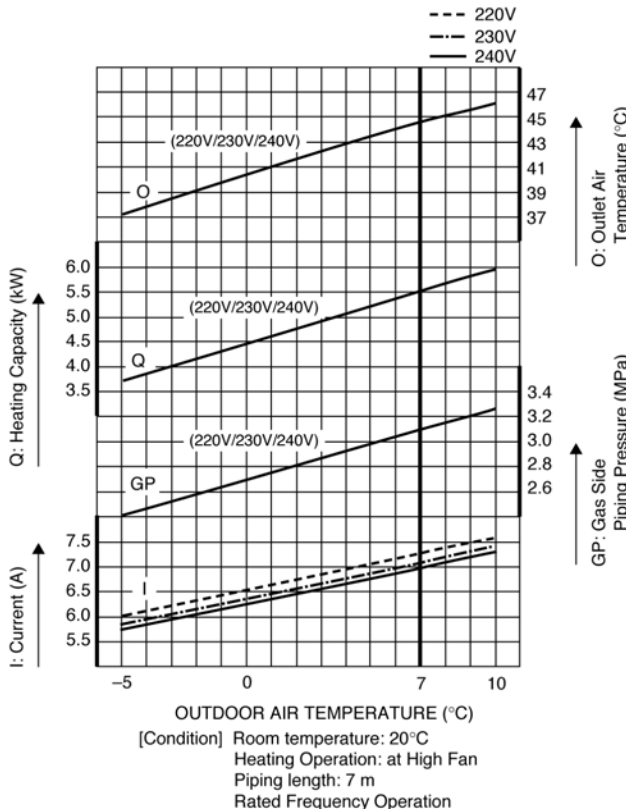

#### • Piping Length Characteristic (Heating)

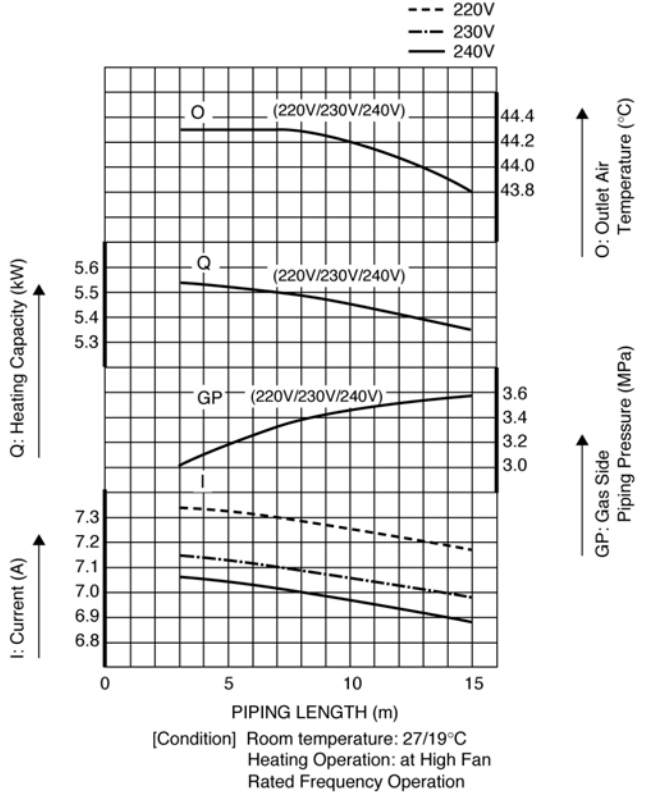

### 14.1.2. CS-E18DKEW CU-E18DKE

#### • Cooling Characteristic

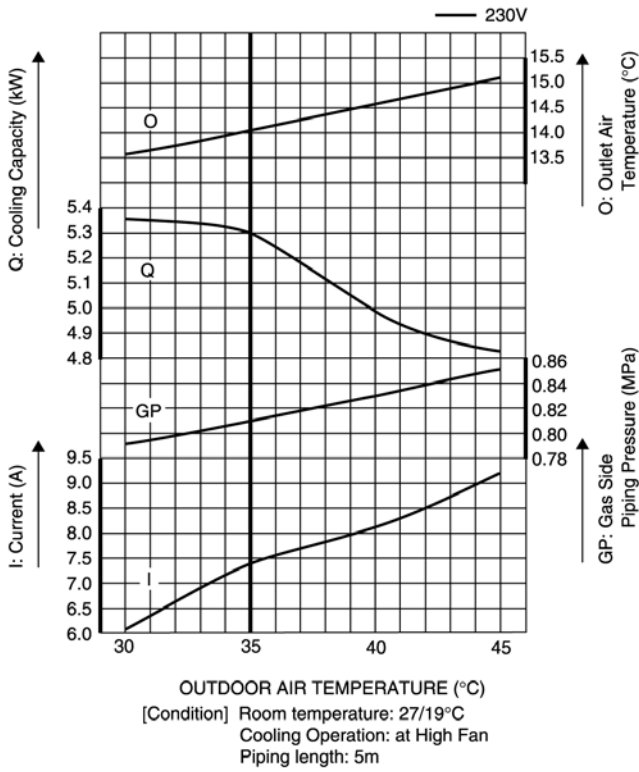

#### • Piping Length Characteristic (Cooling)

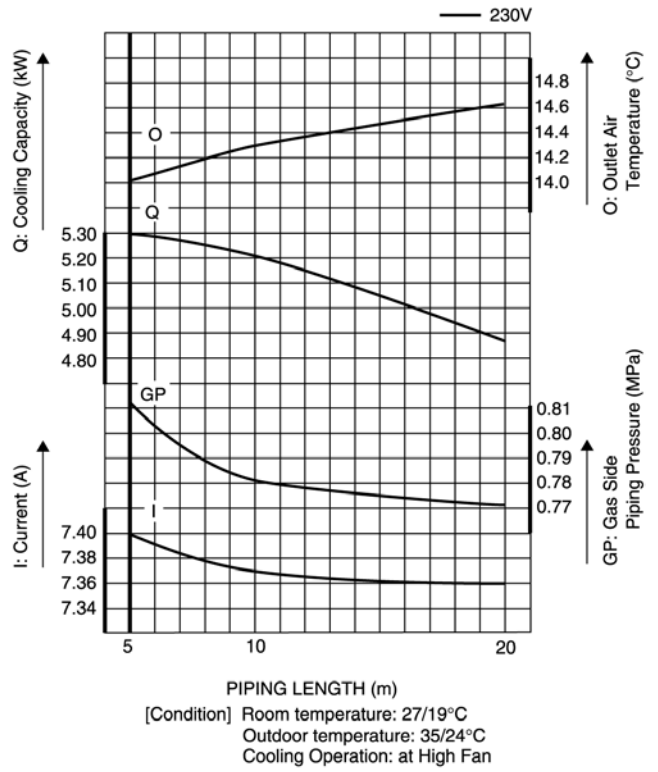

#### • Heating Characteristic

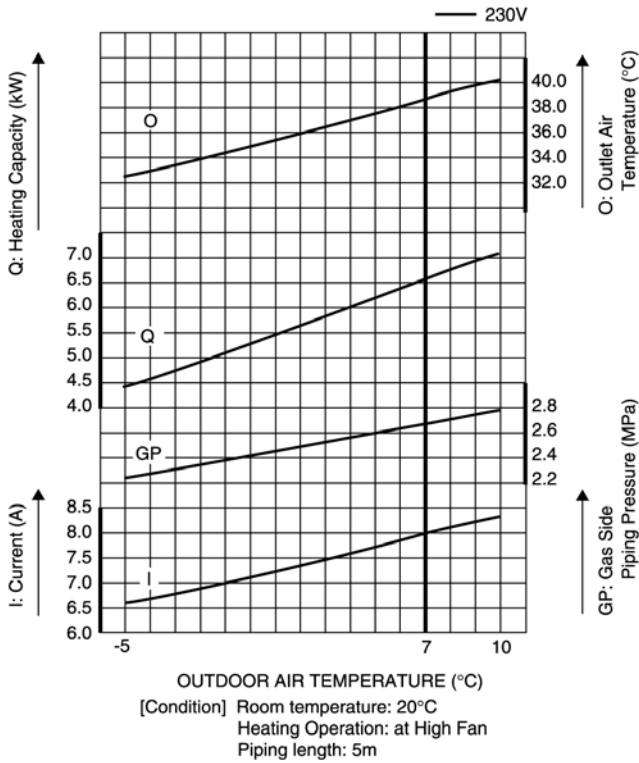

#### • Piping Length Characteristic (Heating)

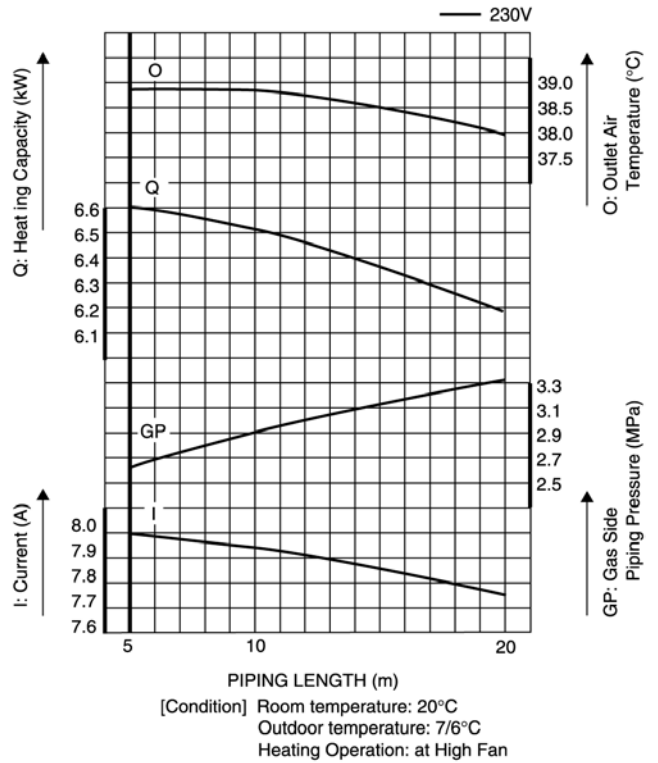

### 14.1.3. CS-E21DKES CU-E21DKE

#### • Cooling Characteristic

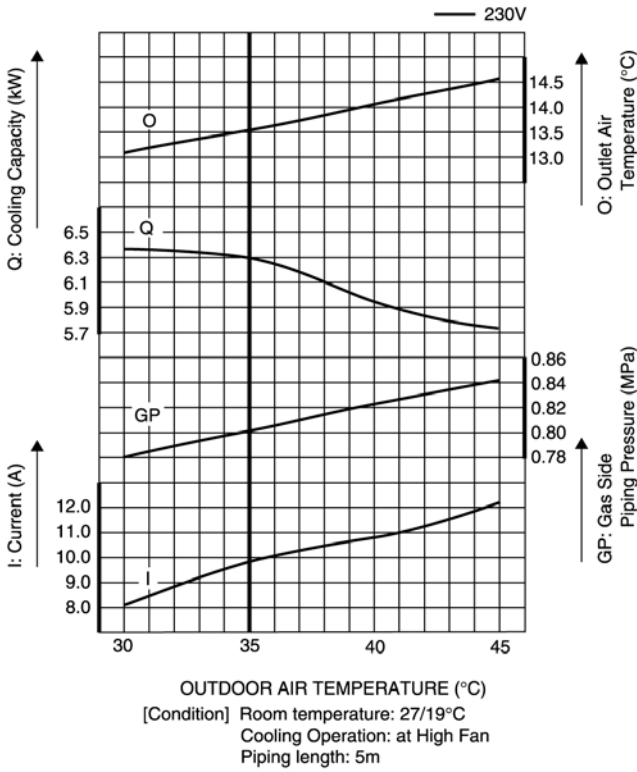

#### • Piping Length Characteristic (Cooling)

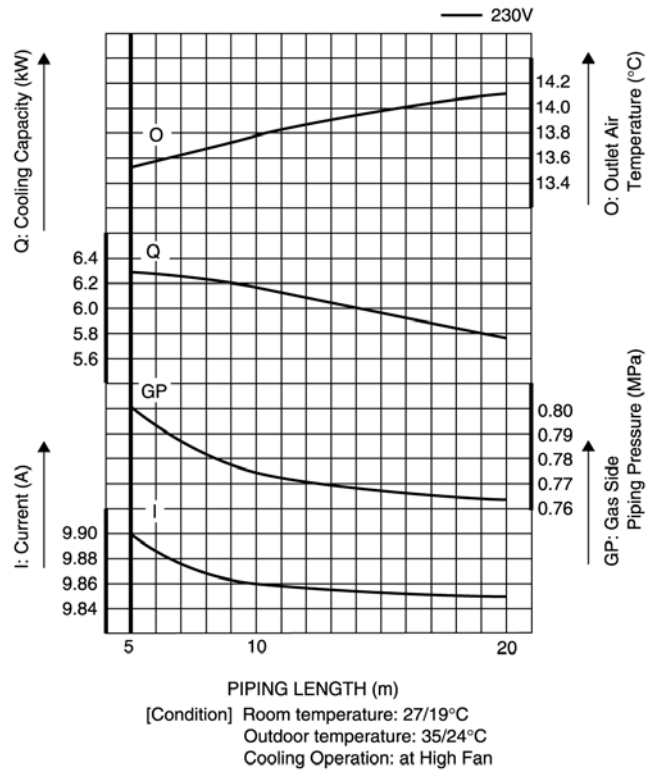

#### • Heating Characteristic

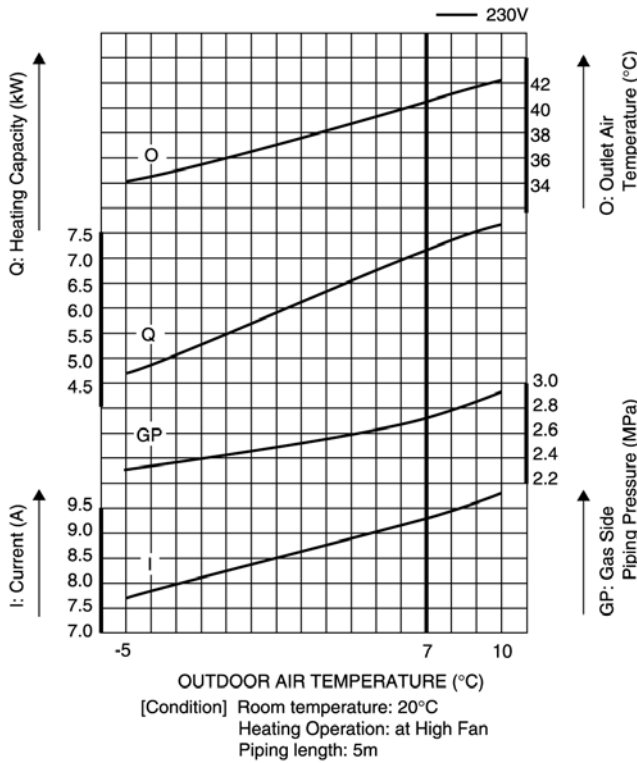

#### • Piping Length Characteristic (Heating)

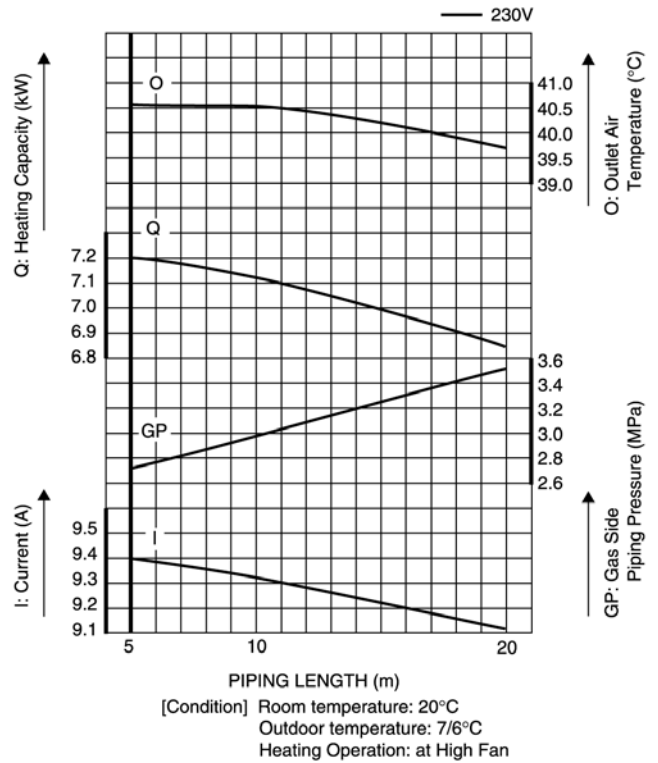

## 14.2. Sensible Capacity Chart

### ● CS-E15DKEW CU-E15DKE

230V Indoor wet bulb temp.	Outdoor Temp. (°C)											
	30			35			40			46		
	TC	SHC	IP	TC	SHC	IP	TC	SHC	IP	TC	SHC	IP
17.0°C	4.36	3.31	1.25	4.08	3.17	1.35	3.79	3.05	1.44	3.45	2.90	1.56
19.0°C				4.40		1.37						
19.5°C	4.79	3.46	1.28	4.48	3.33	1.38	4.17	3.20	1.47	3.79	3.05	1.59
22.0°C	5.22	3.59	1.30	4.88	3.45	1.40	4.54	3.33	1.50	4.13	3.18	1.62

### ● CS-E18DKEW CU-E18DKE

Indoor wet bulb temp.	Outdoor Temp. (°C)											
	30			35			40			46		
	TC	SHC	IP	TC	SHC	IP	TC	SHC	IP	TC	SHC	IP
17.0°C	5.26	3.99	1.51	4.91	3.82	1.63	4.57	3.67	1.74	4.16	3.49	1.88
19.0°C				5.30		1.65						
19.5°C	5.77	4.17	1.54	5.40	4.01	1.66	5.02	3.86	1.77	4.56	3.67	1.91
22.0°C	6.29	4.33	1.57	5.88	4.16	1.69	5.47	4.01	1.80	4.97	3.83	1.95

### ● CS-E21DKES CU-E21DKE

Indoor wet bulb temp.	Outdoor Temp. (°C)											
	30			35			40			46		
	TC	SHC	IP	TC	SHC	IP	TC	SHC	IP	TC	SHC	IP
17.0°C	6.25	4.74	2.02	5.84	4.54	2.18	5.43	4.37	2.33	4.94	4.15	2.51
19.0°C				6.30		2.21						
19.5°C	6.86	4.96	2.06	6.41	4.77	2.22	5.97	4.59	2.37	5.42	4.37	2.56
22.0°C	7.48	5.14	2.10	6.99	4.95	2.26	6.50	4.77	2.42	5.91	4.55	2.61

TC - Total Cooling Capacity (kW)  
 SHC - Sensible Heat Capacity (kW)  
 IP - Input Power (kW)

Indoor 27°C/19°C  
 Outdoor 35°C/24°C



# 15 Exploded View (Indoor Unit)

## 15.1. CS-E15DKEW

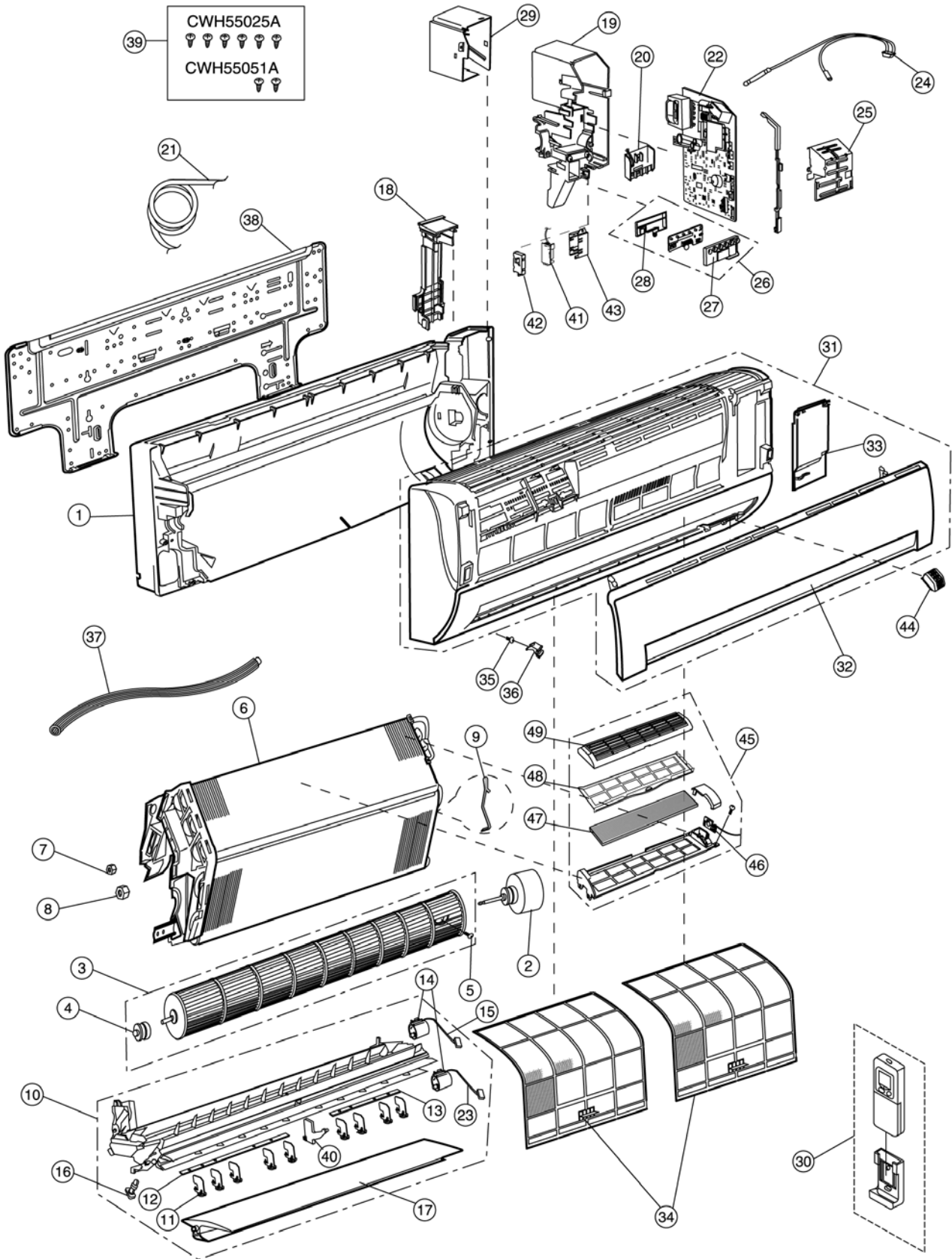

Note:  
 The above exploded view is for the purpose of parts disassembly and replacement.  
 The non-numbered parts are not kept as standard service parts.

## 15.2. CS-E18DKEW CS-E21DKES

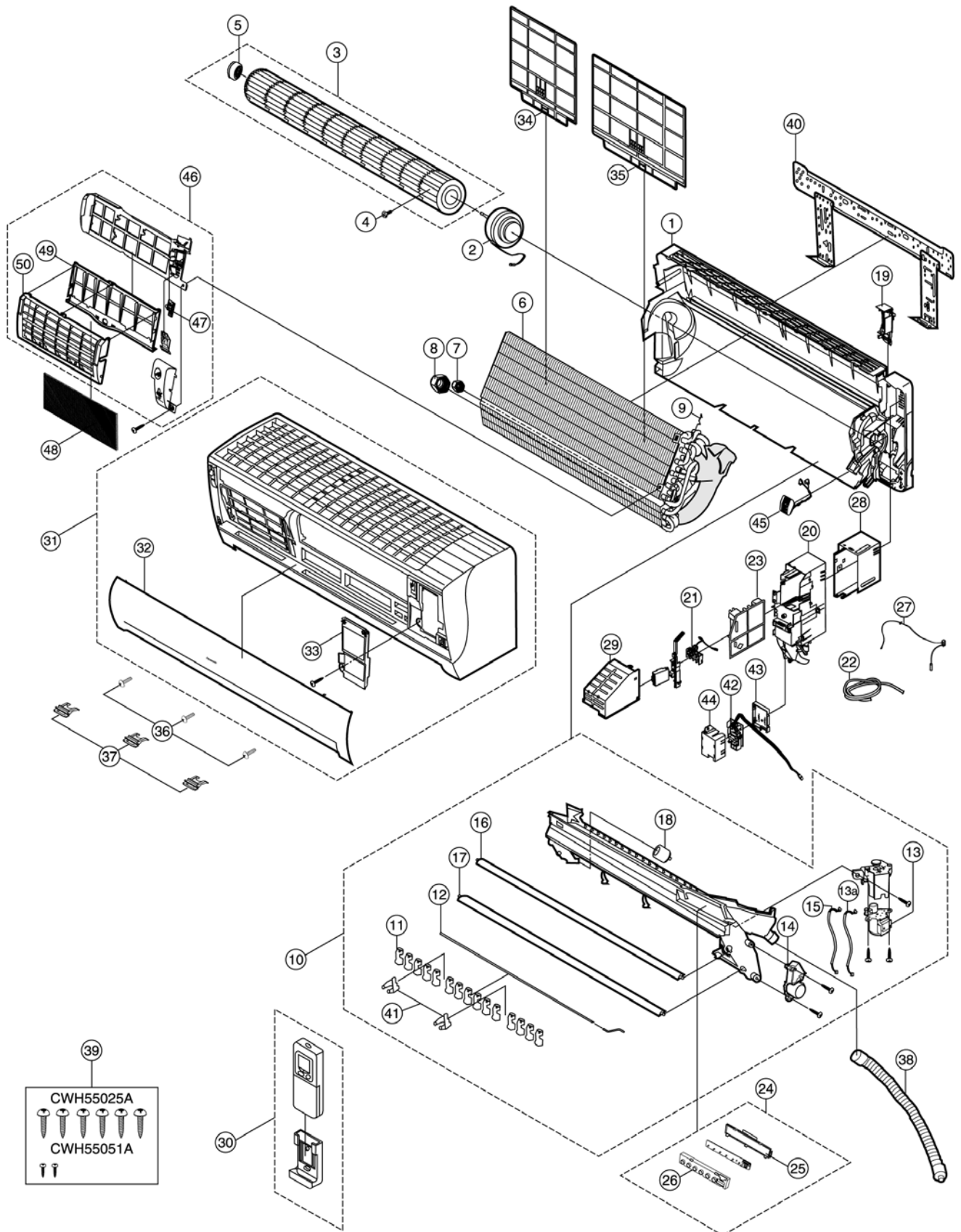

Note:

The above exploded view is for the purpose of parts disassembly and replacement.

The non-numbered parts are not kept as standard service parts.

# 16 Replacement Parts List (Indoor Unit)

## 16.1. CS-E15DKEW

REF. NO.	PART NAME & DESCRIPTION	QTY.	CS-E15DKEW	REMARKS
1	CHASSY COMPLETE	1	CWD50C1431	
2	FAN MOTOR	1	CWA981149	0
3	CROSS FLOW FAN COMPLETE	1	CWH02C1031	
4	BEARING ASS'Y	1	CWH64K007	
5	SCREW - CROSS FLOW FAN	1	CWH4580304	
6	EVAPORATOR	1	CWB30C1726	
7	FLARE NUT	1	CWT25086 (1/4")	
8	FLARE NUT	1	CWT25096 (1/2")	
9	HOLDER SENSOR	1	CWH32143	
10	DISCHARGE GRILLE COMPLETE	1	CWE20C2343	
11	VERTICAL VANE	9	CWE241150	
12	CONNECTING BAR	1	CWE261072	
13	CONNECTING BAR	1	CWE261065	
14	AIR SWING MOTOR	2	CWA98260	0
15	LEAD WIRE - AIR SWING MOTOR	1	CWA67C3849	
16	CAP - DRAIN TRAY	1	CWH521096	
17	HORIZONTAL VANE	1	CWE241173	
18	BACK COVER CHASSIS	1	CWD932454	
19	CONTROL BOARD CASING	1	CWH102259	
20	TERMINAL BOARD COMPLETE	1	CWA28C2082	0
21	POWER SUPPLY CORD	1	-	
22	ELECTRONIC CONTROLLER - MAIN	1	CWA73C1669	0
23	LEAD WIRE - AIR SWING MOTOR	1	CWA67C3977	0
24	SENSOR COMPLETE	1	CWA50C2122	0
25	CONTROL BOARD FRONT COVER	1	CWH13C1120	
26	INDICATOR COMPLETE	1	CWE39C1126	0
27	INDICATOR HOLDER	1	CWD932429	
28	INDICATOR HOLDER	1	CWD932430	
29	CONTROL BOARD TOP COVER	1	CWH131207	
30	REMOTE CONTROL COMPLETE	1	CWA75C2616	0
31	FRONT GRILLE COMPLETE	1	CWE11C3138	0
32	INTAKE GRILLE	1	CWE22C1154	
33	GRILLE DOOR	1	CWE141073	
34	AIR FILTER	2	CWD001144	
35	SCREW - FRONT GRILLE	2	XTT4+16C	
36	CAP - FRONT GRILLE	2	CWH521109	
37	DRAIN HOSE	1	CWH851063	
38	INSTALLATION PLATE	1	CWH361067	
39	BAG COMPLETE - INSTALLATION SCREW	1	CWH82C067	
40	FULCRUM	1	CWH621046	
41	ELECTRONIC CONTROLLER - IONIZER	1	CWA743675	0
42	CASING - IONIZER	1	CWD932464	
43	CASING - IONIZER	1	CWD932431	
44	ION GENERATOR	1	CWH94C0001	
45	SUPERSONIC AIR PURIFYING DEVICE	1	CWH91C1013	
46	ELECTRONIC CONTROLLER SUPERSONIC	1	CWA743874	0
47	SUPER ALLERU BUSTER FILTER	1	CWD00C1133	
48	FRAME FR AIR FILTER SUPERSONIC	1	CWD011026	
49	FRAME FR AIR FILTER SUPERSONIC	1	CWD011027	

(Note)

- All parts are supplied from PHAAM, Malaysia (Vendor Code: 061).
- "O" marked parts are recommended to be kept in stock.

## 16.2. CS-E18DKEW CS-E21DKES

REF. NO.	PART NAME & DESCRIPTION	QTY.	CS-E18DKEW	CS-E21DKES	REMARKS
1	CHASSY COMPLETE	1	CWD50C1382	←	
2	FAN MOTOR	1	CWA981149	←	0
3	CROSS FLOW FAN COMPLETE	1	CWH02C1010	←	
4	SCREW - CROSS FLOW FAN	1	CWH4580304	←	
5	BEARING ASS'Y	1	CWH64K007	←	
6	EVAPORATOR	1	CWB30C1533	CWB30C1532	
7	FLARE NUT	1	CWT25086 (1/4")	←	
8	FLARE NUT	1	CWT25096 (1/2")	←	
9	HOLDER SENSOR	1	CWH32143	←	
10	DISCHARGE GRILLE COMPLETE	1	CWE20C2441	←	
11	VERTICAL VANE	15	CWE241088	←	
12	CONNECTING BAR	1	CWE261025	←	
13	AIR SWING MOTOR	1	CWA98260	←	0
13a	LEAD WIRE - AIR SWING MOTOR	1	CWA67C3849	←	
14	AIR SWING MOTOR	1	CWA98K1008	←	0
15	LEAD WIRE - AIR SWING MOTOR	1	CWA67C3731	←	
16	HORIZONTAL VANE	1	CWE241152A	←	
17	HORIZONTAL VANE	1	CWE241153A	←	
18	CAP - DRAIN TRAY	1	CWH52C1001	←	
19	BACK COVER CHASSIS	1	CWD932162B	←	
20	CONTROL BOARD CASING	1	CWH102250	←	
21	TERMINAL BOARD COMPLETE	1	CWA28C2082	←	0
22	POWER SUPPLY CORD	1	-	-	0
23	ELECTRONIC CONTROLLER - MAIN	1	CWA73C1670	CWA73C1671	0
24	INDICATOR COMPLETE	1	CWE39C1116	←	0
25	INDICATOR HOLDER	1	CWD932435	←	
26	INDICATOR HOLDER	1	CWD932436	←	
27	SENSOR COMPLETE	1	CWA50C2122	←	0
28	CONTROL BOARD TOP COVER	1	CWH131209	←	
29	CONTROL BOARD FRONT COVER	1	CWH131210	←	
30	REMOTE CONTROL COMPLETE	1	CWA75C2616	←	0
31	FRONT GRILLE COMPLETE	1	CWE11C3160	←	0
32	INTAKE GRILLE COMPLETE	1	CWE22C1159	←	0
33	GRILLE DOOR	1	CWE141076	←	
34	AIR FILTER (L)	1	CWD001137	←	
35	AIR FILTER (R)	1	CWD001138	←	
36	SCREW - FRONT GRILLE	3	XTT4+16C	←	
37	CAP - FRONT GRILLE	3	CWH521062A	←	
38	DRAIN HOSE	1	CWH851063	←	
39	BAG COMPLETE - INSTALLATION SCREW	1	CWH82C067	←	
40	INSTALLATION PLATE	1	CWH36K1007	←	
41	FULCRUM	2	CWH621047	←	
42	ELECTRONIC CONTROLLER - IONIZER	1	CWA743675	←	0
43	CASING - IONIZER	1	CWD932464	←	
44	CASING - IONIZER	1	CWD932527	←	
45	ION GENERATOR	1	CWH94C0001	←	
46	SUPERSONIC AIR PURIFYING DEVICE	1	CWH91C1013	←	
47	ELECTRONIC CONTROLLER SUPERSONIC	1	CWA743874	←	0
48	SUPER ALLERU BUSTER FILTER	1	CWD00C1133	←	
49	FRAME FR AIR FILTER SUPERSONIC	1	CWD011026	←	
50	FRAME FR AIR FILTER SUPERSONIC	1	CWD011027	←	

(Note)

- All parts are supplied from PHAAM, Malaysia (Vendor Code: 061).
- "O" marked parts are recommended to be kept in stock.

# 17 Exploded View (Outdoor Unit)

## 17.1. CU-E15DKE CU-E18DKE CU-E21DKE

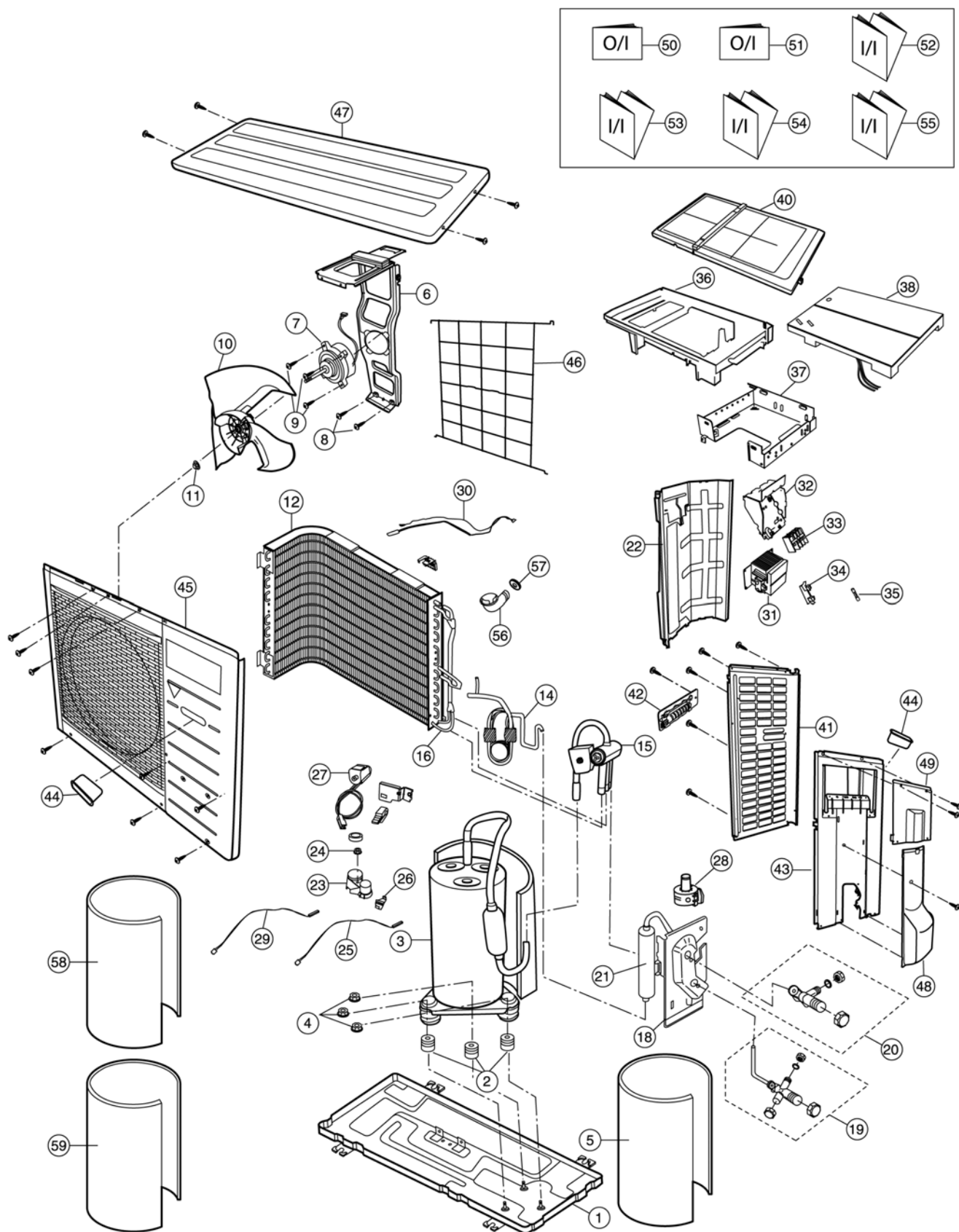

Note:  
 The above exploded view is for the purpose of parts disassembly and replacement.  
 The non-numbered parts are not kept as standard service parts.

# 18 Replacement Parts List (Outdoor Unit)

## 18.1. CU-E15DKE CU-E18DKE CU-E21DKE

REF NO.	DESCRIPTION & NAME	QTY.	CU-E15DKE	CU-E18DKE	CU-E21DKE	REMARKS
1	CHASSY ASSY	1	CWD50K2085	←	←	
2	ANTI-VIBRATION BUSHING	3	CWH50077	←	←	
3	COMPRESSOR	1	5CS130XAD04	←	←	O
4	NUT-COMPRESSOR MOUNT	3	CWH56000	←	←	
5	SOUND PROOF MATERIAL	1	CWG302302	←	←	
6	FAN MOTOR BRACKET	1	CWD541084	CWD541054	←	
7	FAN MOTOR	1	CWA981166	←	←	O
8	SCREW - FAN MOTOR BRACKET	2	CWH551060	←	←	
9	SCREW - FAN MOTOR MOUNT	3	CWH551106	←	←	
10	PROPELLER FAN ASSY	1	CWH03K1016	←	←	
11	NUT - PROPELLER FAN	1	CWH56053	←	←	
12	CONDENSER	1	CWB32C1583	CWB32C1527	CWB32C1526	
14	TUBE ASS'Y COMPLETE (CAP TUBE/EXP.VALVE)	1	CWT023679	←	CWT022997	O
15	4 WAYS VALVE	1	CWB001026	←	←	
16	STRAINER	1	CWB11094	←	←	
18	HOLDER - COUPLING	1	CWH351035	←	←	
19	3 WAYS VALVE (GAS)	1	CWB011170	←	←	O
20	2 WAYS VALVE (LIQUID)	1	CWB021135	←	←	O
21	OIL SEPARATER ASS'Y	1	-	-	CWB16K1008	O
22	SOUND PROOF BOARD	1	CWH151050	←	←	
23	TERMINAL COVER	1	CWH171001	←	←	
24	NUT-TERMINAL COVER	1	CWH7080300	←	←	
25	SENSOR COMPLETE (COMP. TOP)	1	CWA50C2185	←	←	
26	HOLDER SENSOR	1	CWH321010	←	←	
27	V-COIL COMPLETE (4-WAYS VALVE)	1	CWA43C2168	←	←	
28	V-COIL COMPLETE (EXPAND VALVE)	1	CWA43C2141	←	←	
29	SENSOR COMPLETE (COMP. DISC.)	1	CWA50C2180	←	←	
30	SENSOR COMPLETE	1	CWA50C2181	←	←	
31	REACTOR	1	CWA421069	←	←	
32	CONTROL BOARD CASING (SIDE)	1	CWH102273	←	←	
33	TERMINAL BOARD ASSY	1	CWA28K1110	←	←	
34	FUSE HOLDERS	1	K3GB1PH00016	-	-	
35	FUSE	1	-	-	-	
36	CONTROL BOARD CASING (TOP)	1	CWH102204	←	←	
37	CONTROL BOARD CASING (BOTTOM)	1	CWH102282	←	←	
38	ELECTRONIC CONTROLLER - MAIN	1	CWA73C1764R	CWA73C1765R	CWA73C1766R	O
40	CONTROL BOARD COVER (TOP)	1	CWH131167	←	←	
41	CABINET SIDE PLATE (LEFT)	1	CWE041082A	←	←	
42	HANDLE	1	CWE161010	←	←	
43	CABINET SIDE PLATE (RIGHT)	1	CWE041083A	←	←	
44	HANDLE	2	CWE16000E	←	←	
45	CABINET FRONT PLATE CO.	1	CWE06K1043	←	←	
46	WIRE NET	1	CWD041041A	←	←	
47	CABINET TOP PLATE	1	CWE031031A	←	←	
48	CONTROL BOARD COVER (BOTTOM)	1	CWH131168	←	←	
49	CONTROL BOARD COVER (TOP)	1	CWH131169A	←	←	
50	OPERATING INSTRUCTION	1	CWF564673	CWF564607	←	
51	OPERATING INSTRUCTION	1	CWF564674	CWF564608	←	
52	INSTALLATION INSTRUCTION	1	CWF612783	CWF612720	←	
53	INSTALLATION INSTRUCTION	1	CWF612784	CWF612721	←	
54	INSTALLATION INSTRUCTION	1	CWF612785	CWF612722	←	
55	INSTALLATION INSTRUCTION	1	CWF612786	CWF612723	←	
56	DRAIN HOSE	1	CWH5850080	←	←	
57	PACKING	1	CWB81012	←	←	
58	SOUND PROOF MATERIAL	1	CWG302290	CWG302270	←	
59	SOUND PROOF MATERIAL	1	CWG302301	CWG302300	←	

(Note)

- All parts are supplied from PHAAM, Malaysia (Vendor Code: 061).
- "O" marked parts are recommended to be kept in stock.

**CS-E15DKEW**  
**CS-E18DKEW**  
**CS-E21DKES**

Fig. 1

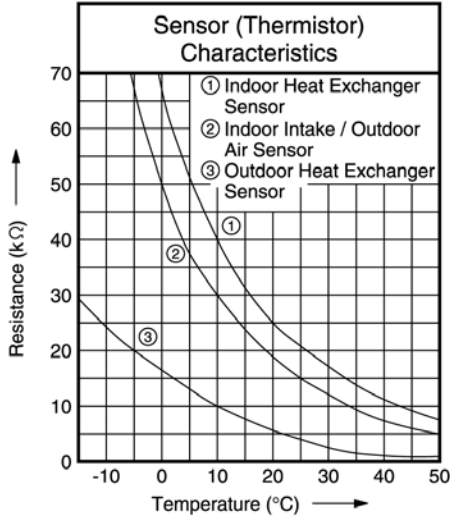
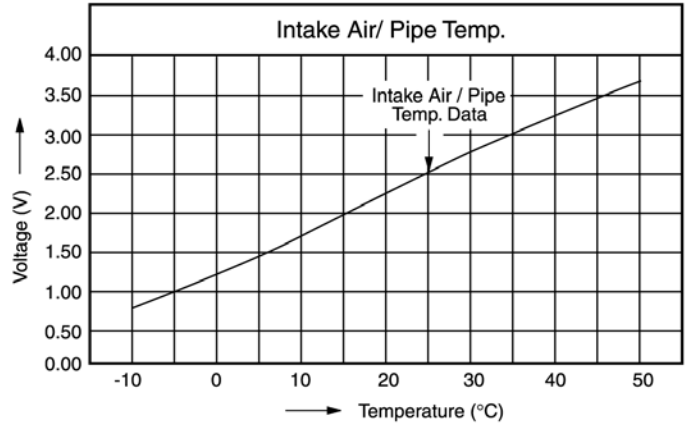

Fig. 2



**CU-E15DKE**  
**CU-E18DKE**  
**CU-E21DKE**

Fig. 3

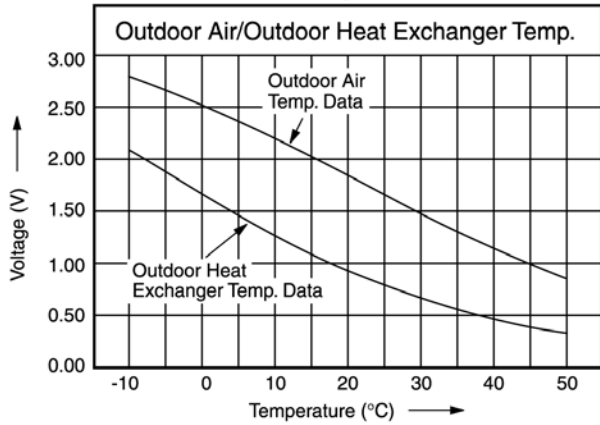

Fig. 4

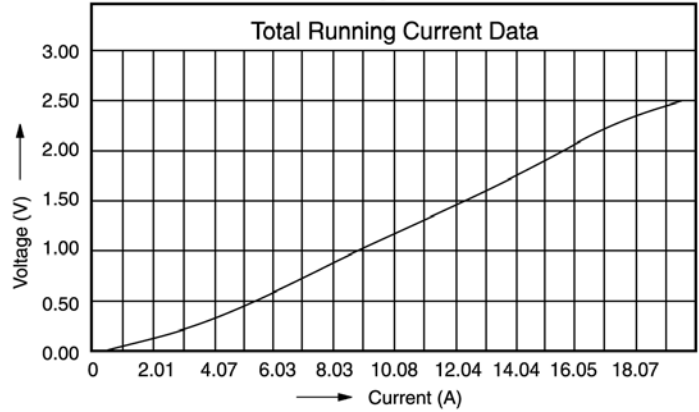

Fig. 5

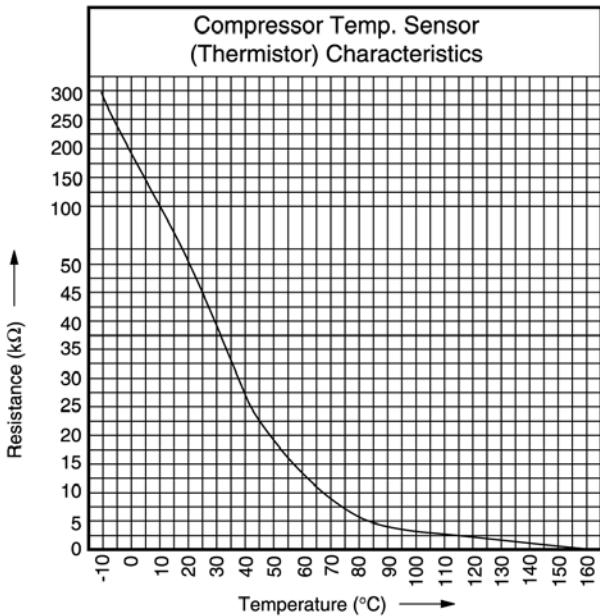

Fig. 6

